

**SAMSUNG**

# ECO HEATING SYSTEM

**OUTDOOR UNIT    CONTROL KIT**

Model: AE050JXYDEH/EU    MIM-E03BN

Basic Model: AE090JXYDEH/EU    MIM-E03AN

# ***SERVICE*** *Manual*

## ECO HEATING SYSTEM



MIM-E03BN

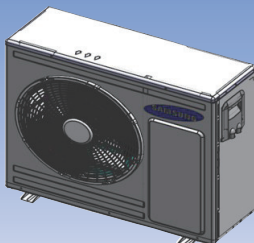

AE050JXYDEH/EU

## CONTENTS

1. Precautions
2. Product Specifications
3. Disassembly and Reassembly
4. Troubleshooting
5. PCB Diagram
6. Wiring Diagram
7. Reference Sheet

# Contents

<b>1. Precautions</b> .....	<b>3</b>
1-1 Precautions for the Service .....	3
1-2 Precautions related to static electricity and PL.....	3
1-3 Precautions for the Safety .....	4
1-4 Precautions for handling a system containing refrigerants .....	5
1-5 Precautions for the brazing .....	5
1-6 Precautions for charging refrigerants .....	5
<b>2. General Overview</b> .....	<b>6</b>
2-1 Features of the System .....	6
2-1-1 Key features of the Monobloc.....	7
2-2 Product Specifications.....	8
2-2-1 MONO Unit.....	8
2-3 Specifications of optional items.....	9
2-3-1 Accessories.....	9
<b>3. Disassembly and Reassembly</b> .....	<b>11</b>
3-1 EHS Control Kit .....	12
3-2 Outdoor Unit.....	14
<b>4. Troubleshooting</b> .....	<b>23</b>
4-1 Wired remote controller.....	23
4-2 Troubleshooting by symptoms .....	26
4-2-1 Communication error after finishing Tracking .....	26
4-3 Control Kit.....	27
4-3-1 EEPROM error .....	27
4-3-2 <i>E653</i> : Error due to abnormal data of Wired remote controller thermistor value .....	28
4-3-3 <i>E911</i> : Error due to abnormal data of Water outlet thermistor value.....	29
4-3-4 <i>E912</i> : Error due to abnormal data of DHW tank thermistor value.....	30
4-3-5 Control Kit temperature sensor(open/short).....	31
4-3-6 Communication error after finishing Tracking(Hydro unit).....	32
4-4 Items to check before diagnostics .....	33
4-4-1 Test run mode and view mode.....	33
4-4-2 Troubleshooting for outdoor unit .....	34
4-5 Troubleshooting by symptoms .....	36
4-5-1 Communication error after finishing tracking (E202) .....	36
4-5-2 Time out (1min.) of communication error between MAIN PBA and INV. PBA (E203) .....	37

# Contents

4-5-3 Temperature sensor error (E221, E231, E251, E320) .....	38
4-5-4 Fan error (E458, E475).....	39
4-5-5 Compressor error (E461, E467) .....	41
4-5-6 Current trip error (E462, E463) .....	42
4-5-7 IPM(IGBT module) over current error (E464).....	43
4-5-8 DC-link voltage under/over error (E466) .....	45
4-5-9 GAS leak error(E554) .....	46
4-5-10 The other errors .....	47
4-5-11 In case of heating at the cooling mode or cooling at the heating mode.....	48
4-5-12 Outdoor unit is not powered on – Initial diagnosis.....	50
4-5-13 Outdoor unit power supply error .....	51
<b>5. PCB Diagram.....</b>	<b>52</b>
5-1 Control Kit.....	52
5-2 Outdoor Unit.....	54
<b>6. Wiring Diagram .....</b>	<b>57</b>
6-1 Control Kit.....	57
6-2 Outdoor Unit.....	58
<b>7. Reference Sheet .....</b>	<b>59</b>
7-1 Index for Model Name.....	59
7-1-1 Outdoor Unit .....	59
7-2 Refrigerant Circuit Diagram .....	60
7-3 FSV data check and update using S-Net Pro2 .....	61
7-4 EHS FSV Values Import and Export .....	62

---

# 1. Precautions

---

## 1-1 Precautions for the Service

---

- **Use the standard parts when replacing the electric parts.**
  - Confirm the model name, rated voltage, rated current of the electric parts.
- **When repairing the equipment, connection of the harness parts must be firm and solid.**
  - A loose connection may cause noise or other malfunction.
- **When assembling and disassembling the equipment while it is laid down, lay it on soft cloth.**
  - Otherwise it may scratch the back of the exterior of the product.
- **Remove dust or dirt completely from the housing block, wiring block and service parts during repair.**
  - This helps prevent the danger of fire caused by tracking or short circuit.
- **Fasten the valve caps of service valves and charging valves of outdoor unit as much as possible using adjustable wrenches.**
- **Check the status of the components' assembly after repair service.**
  - The status must be the same as before the repair service.

## 1-2 Precautions related to static electricity and PL

---

- **The PCB power supply block is susceptible to static electricity. Therefore, care must be taken during repair or measuring while the power is on.**
  - Wear insulation gloves for PCB repair or measuring.
- **Check whether the installation location is at least two meters away from other electronic products such as TV, video, or audio.**
  - Otherwise, the video quality might be degraded or noise might be generated.
- **Do not let end users repair the products themselves.**
  - Unauthorized disassembly might cause electric shock or fire.



## 1-3 Precautions for the Safety

---

- **Do not pull any electric wires and do not touch an auxiliary power switch with a wet hand.**
  - There is a danger of electric shock or fire.
- **In case any wire or power plug has been damaged, replace it to eliminate any possible danger.**
- **Do not bend the power cord by force and do not put any heavy object on the power cord.**
  - There is a danger of electric shock or fire.
- **Do not use multi socket.**
  - There is a danger of electric shock or fire.
- **Ground the product if necessary.**
  - Be sure to ground the product if there is any danger of electric leakage due to water or moisture.
- **Be sure to turn off the auxiliary power switch or pull out the power plug during replacement or repair of electric parts.**
  - There is a danger of electric shock.
- **In case the product will not be in use for a long time, the battery of remote control should be kept separately.**
  - Leakage of inside fluid can cause break down of remote control.
- **The installation must be done by the manufacturer or its service agent or a similar qualified person in order to avoid a hazard.**
  - Installation by an unqualified person may cause a water leakage, electric shock or fire and so on.
- **The electric work must be done by service agent or similarly qualified persons according to national wiring regulations and use only rated cable.**
  - If the capacity of the power cable is insufficient or electric work is not properly completed, electric shock or fire may occur.
- **Use only rated parts and tools.**
  - If you don't use the rated parts and tools, it can cause trouble with the air conditioner and bring about injury.
- **If any gas or impurities except R410A refrigerant come into the refrigerant pipe, serious problem may occur and it may cause injury.**
- **Leak test must be done using only Nitrogen(NO<sub>2</sub>)gas.**

- R410A refrigerant is used for EHS.
  - When using R410A, moisture or foreign substances may affect to the capacity and reliability of the product. Safety precautions must be taken when installing the refrigerant pipe.
  - The design pressure of the unit is 4.1MPa. Select appropriate material and thickness according to the regulations.
  - R410A is a quasi-azeotrope of two refrigerants.  
Make sure to charge liquid one when adding refrigerant.  
If you charge gaseous refrigerant, it may affect the capacity and reliability of the product as a result of change formation of the refrigerant.

## 1-4 Precautions for handling a system containing refrigerants

---

All system containing refrigerants shall be removed under regional regulations prior to the disposal to prevent the potential health and environmental consequences.

- **Harmful for human body**
  - When emitted liquid refrigerant contacts human body, contacted area may get frostbite, blister or become numb.
  - If refrigerant leaks in airtight area, lack of oxygen may cause suffocation. When refrigerant is heated, it may generate harmful gas.
- **Precautions for handling container**
  - Do not apply shock or heat to the refrigerant container.

## 1-5 Precautions for the brazing

---

- **Clear any dangerous or inflammable materials in surrounding environment.**
- **Make sure to empty the remaining refrigerant in the product or pipe before brazing.**
  - Brazing with the refrigerant still remaining in the product or pipe may cause poor result and generate harmful gas. Furthermore, pressure of the refrigerant may increase and cause damage to the leaking part. This may lead harmful refrigerant and oil to spurt out which can be dangerous for service personnel.
- **Use nitrogen gas to get rid of the oxide forming during brazing.**
  - Using other type of gas may cause damage to the product or the exterior.

## 1-6 Precautions for charging refrigerants

---

- **Add quantity of the refrigerant using a scale and perform a test operation with S-net.**
  - Product performance may decrease if you add excessive amount of refrigerant.
- **Do not charge refrigerants while heating the container up.**
  - The container may get damaged by the heat and result in explosions.
- **Do not operate the product without pressure switch(for product protection) and sensor.**
  - If there are any internal blockage, high refrigerant pressure increase may damage the product or exterior.

## 2. General Overview

### 2-1 Features of the System

#### POWER SAVING

**EHS(Eco Heating System)** considers the trend in air conditioner use. It optimizes the energy efficiency of loads ranging from partial to full. It achieves an excellent energy effect for the users of the air conditioner.

#### Samsung patented compressor

Samsung has been researching and developing compressors since the 70's. It has developed power saving compressors for more than thirty years.

The **EHS(Eco Heating System)** compressor adopts a double-rotor BLDC compressor with permanent magnets made by Samsung. Electricity for the compressor rotor is obtained from a neodymium-iron-boron permanent magnetic material (boron magnet can attract iron material weighing 1000 times its own weight.) It strengthens the rotary moment of the compressor to maximize the entire efficiency of the compressor.

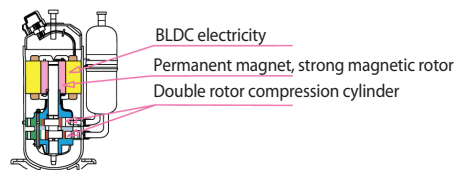

Nd-Fe-B Neodymium-Iron-Boron magnet

**SAMSUNG's** double-rotor compressor has the upper and lower rotors designed symmetrically. The double rotor in symmetry can remove vibrations caused by the eccentric design of the cylinder.

2 rotors balancing the rotary moment

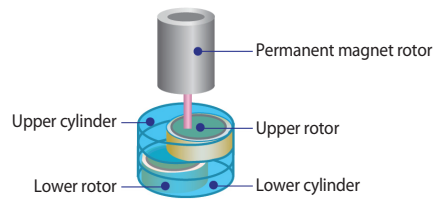
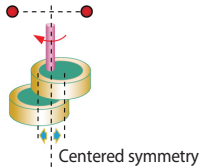

## 2-1-1 Key features of the Monobloc

### ■ Easy installation

No need to install the refrigerant lines in the system. Users can run the system after connecting water pipes only.

### ■ Integrated Heating & Cooling system

Plate Heat exchanger is an integral part in heating & cooling system. For user's convenience, PHE is integrated into the system. This concept will help space saving and lower costs for pipe line reduction.

### ■ Running Costs-Reduction of Up to 32.4%



Samsung EHS, known for its world class efficiency (12kW floor heating system with COP of 4.51), can reduce 32.4% of your running costs as compared to a gas boiler.

### ■ High Performance at Low Temperature

Samsung EHS is made up of an inverter compressor optimally operated according to the outdoor temperature, offering heating performance of 90% at -10°C and reliable frost protection at -25°C.

## 2-2 Product Specifications

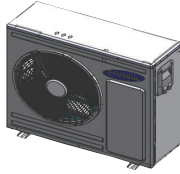
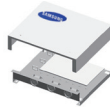
### 2-2-1 MONO Unit

Item				AE050JXYDEH	
				1phase 5kW	
Image	Outdoor unit				
	Control Kit				
	Remote Controller				
A2W Condition #1. (A7/W35) *1	Nominal Capacity	Heating	W	5,000	
			Btu/h	17,100	
		Cooling	W	5,000	
			Btu/h	17,100	
	Power Input(Nominal)	Heating	W	1,060	
		Cooling	W	1,210	
	Current Input(Nominal)	Heating	A	5.1	
		Cooling	A	5.7	
COP (Nominal Heating)			W/W	4.72	
EER (Nominal Cooling)			W/W	4.13	
SCOP				A+++	
A2/W35	Capacity	Heating	W	4,500	
	COP		W/W	3.46	
A-7/W35	Capacity	Heating	W	4,700	
	COP		W/W	2.69	
Field Wiring	MCA		A	20	
	MFA		A	25	
	Power Source Wire		m <sup>2</sup>	L<10m, 2.5 <sup>↑</sup> 10m<L<20m, 4.0 <sup>↑</sup>	
	Transmission Cable		m <sup>2</sup>	0.75 <sup>↑</sup>	
Water Connections	Water Flow Rate (Heating/Cooling)		LPM	14.5/14.5	
	Water Pressure (Max)		bar	3	
	Water Pipe	Inlet	Φ, inch	BSPP male 1"	
		Outlet	Φ, inch	BSPP male 1"	
	Leaving Water Temperature	Heating	°C	25~55	
Cooling		°C	5~25		
Refrigerant	Type		-	R410A	
	Control Method		-	EEV	
	Factory Charging		g	1,150	
Power Supply			Φ, #, V, Hz	E(220~240V, 50Hz, 1Φ)	
Sound *3	Sound Pressure	Heating Std High	dB(A)	45	
		Cooling Std High	dB(A)	45	
	Sound Power	Heating Std High	dB	61	
External Dimension	Net Weight		kg	59	
	Shipping Weight		kg	63	
	Net Dimensions (WxHxD)		mm	880 x 798 x 310	
	Shipping Dimensions (WxHxD)		mm	1,023 x 904 x 413	
Operating Temp. Range	A2W	Heating	°C	-25~35	
		Cooling	°C	10~46	
		D.Hot Water	°C	-25~43	

\*1) A2W Condition #1 : (Heating) Water In/Out 30°C/35°C, Outdoor Air 7°C DB/6°C WB; (Cooling) Water In/Out 23°C/18°C, Outdoor Air 35°C DB.





\*2) Sound pressure was acquired in an anechoic room. Thus actual noise level may be different depending on the installation conditions.

## 2-3 Specifications of optional items

### 2-3-1 Accessories



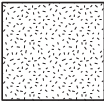





Item	Description	Code No.	Q'ty	Remark
	Drain Plug	DB67-20011A	1	Essential Offer (Outdoor Unit)
	Rubber Leg	DB73-20134A	4	
	MANUAL INSTALL (Outdoor Unit)	DB68-05133A	1	
	Assy Connector Wire (Wire for Silent mode)	DB93-08678A	1	
	MANUAL USERS (CONTROL KIT)	DB68-05402A	1	Essential Offer (Control Kit)
	MANUAL INSTALL (CONTROL KIT)	DB68-05388A	1	
	Switch-Flow	DB34-00084A	1	
	Wired remote controller	DB93-11251L	1	
	Connector Wire (Smart Grid, 2000mm)	DB93-13255A	1	
	SENSOR TEMP	DB32-00213A	1	
	Thermistor (Water Tank)	DB95-05023A	1	
	SENSOR TEMP	DB32-00217A	1	
	HOLDER SENSOR	DB61-05217A	2	
	SPRING ETC-SENSOR	DB81-00635A	2	
	CABLE TIE	DB65-10088C	4	

## Accessories

Item	Description	Code No.	Q'ty	Remark
	TAPE-HANDLE CABI SIDE	DB74-00039D	2	Essential Offer (Control Kit)
	RUBBER-PIPE	DB73-00436B	2	
	INSULATION-BASE	DB72-00401F	2	
	ASSY CONNECTOR WIRE-CLIP (Back-up heater connector(Brown))	DB93-08924R	1	
	LEAD CONNECTOR (Back-up heater connector (Red))	DB39-00941A	1	
	LEAD CONNECTOR (Back-up heater connector(White))	DB39-00941B	1	

### 3. Disassembly and Reassembly

#### ■ Hand Tool sets

Item	Remark
+Screw Driver	
Adjustable wrench	
-Screw Driver	
Nipper	
Electric Motion Driver	
L-Wrench	
Torque Lench	
Latchet Lench	



### 3-1 EHS Control Kit

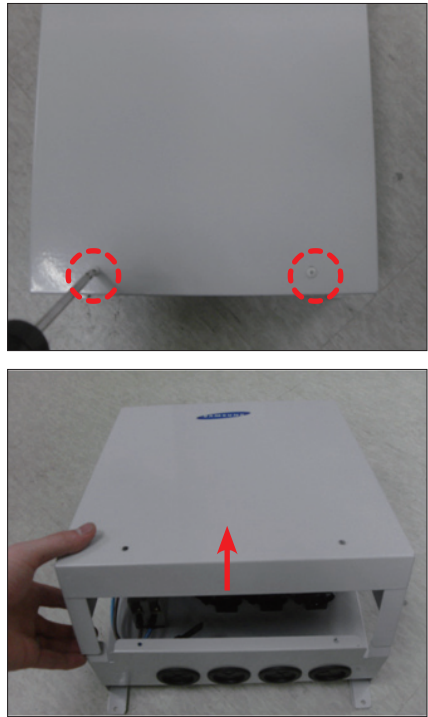
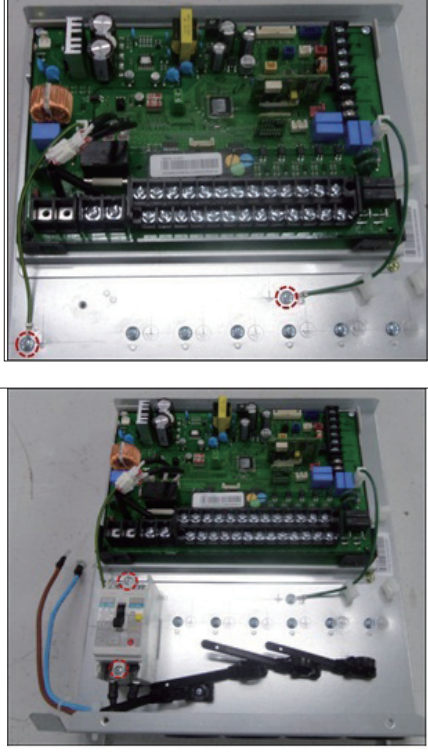

Be sure that the power switch is in the OFF and the power source cord shall be unplugged prior to disassembly and reassembly works.



No	Parts	Procedure	Remark
1	CABINET TOP	<p><b>⚠ You must turn off the power before disassembling.</b></p> <p>1) Unscrew and remove the two screws on the CABINET TOP. (Use '+' type screw driver)</p> <p>2) Remove the CABINET TOP.</p>	
2	ELCB	<p>1) Unscrew and remove the two screws of the power supply cable on the terminal block. (Use '+' type screw driver)</p> <p>2) Unscrew and remove the two screws on the top &amp; bottom of the ELCB. (Use '+' type screw driver)</p>	

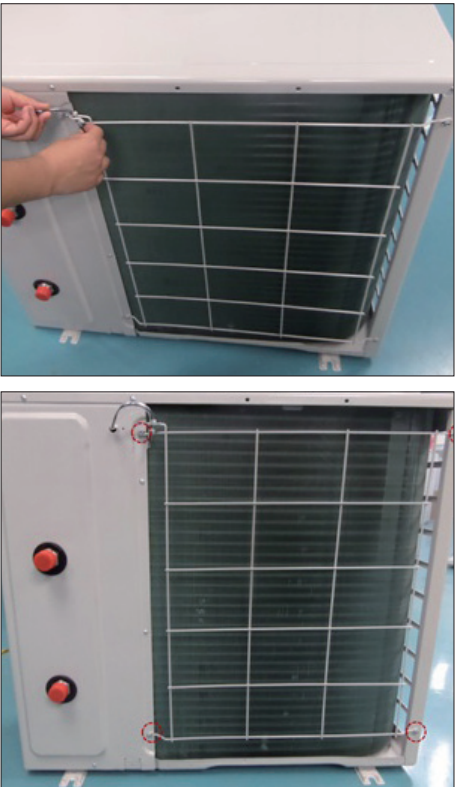

No	Parts	Procedure	Remark
3	ASSY PCB MAIN OUT	<p>1) Unscrew and remove the earth screw on the CABINET BOTTOM. (Use '+' type screw driver)</p> <p>2) Unscrew and remove the two screws. (Use '+' type screw driver)</p> <p>3) Firstly pull the PCB along red arrow ,then pull the PCB out along yellow arrow.</p> <p><b>⚠ Please note that PCB support may be broken by your excessive pulling.</b></p>	

## 3-2 Outdoor Unit

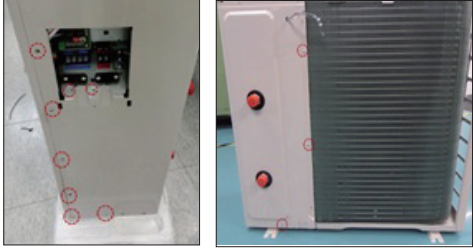

### ■ AE050JXYDEH

No	Parts	Procedure	Remark
1	CABI TOP	<p><b>⚠ You must turn off the power before disassembling.</b></p> <p>1) Unscrew and remove the ten screws on each side of the CABI TOP. (Use '+' type screw driver)</p>	
2	ASSY COVER CONTROL	<p>1) Unscrew and remove the one screw on the ASSY COVER CONTROL. (Use '+' type screw driver)</p>	
3	GUARD COND	<p>1) Pull the sensor from Guard Cond.</p> <p>2) Unscrew and remove the four screws on the GUARD COND. (Use '+' type screw driver)</p>	

No	Parts	Procedure	Remark
4	CABI SIDE RH	<p>1) Unscrew and remove the eleven screws on each side of the CABI BACK RH. (Use '+' type screw driver)</p> <p>2) Pull the sensor from the CABI SIDE RH.</p>	 
5	CABI FRONT	<p>1) Unscrew and remove the 9 screws on the CABI FRONT. (Use '+' type screw driver)</p>	

No	Parts	Procedure	Remark
5	CABI FRONT	1) Unscrew and remove the 9 screws on each side the CABI FRONT. (Use '+' type screw driver)	
6	FAN	1) Turn the one nut as shown in the picture and remove it. (Use adjustable wrench)	

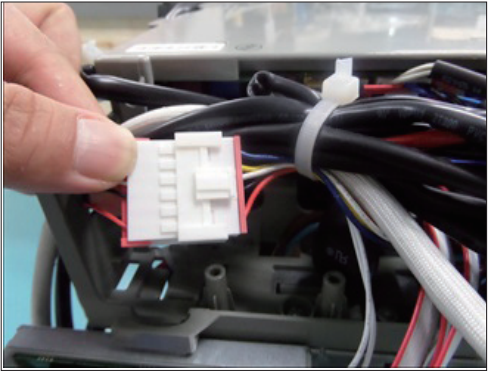



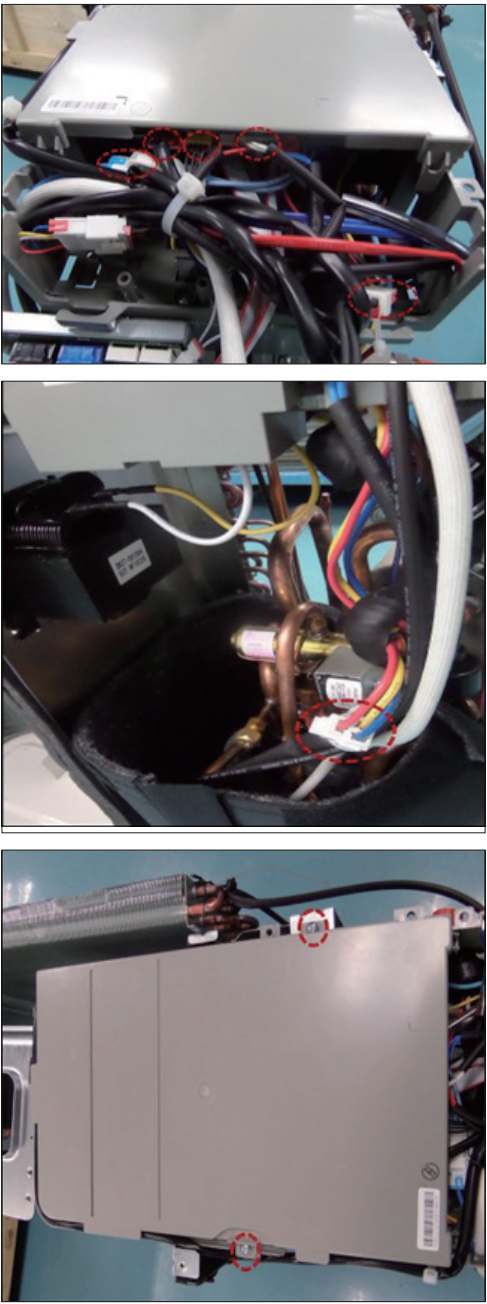

No	Parts	Procedure	Remark
7	MOTOR	1) Remove the fan. 2) Unscrew and remove the four motor screws. (Use '+' type screw driver)  3) Disconnect the motor wire from the Ass'y Control Out.	 
8	BRACKET	1) Unscrew and remove the two screws on the BRACKET MOTOR. (Use '+' type screw driver)	

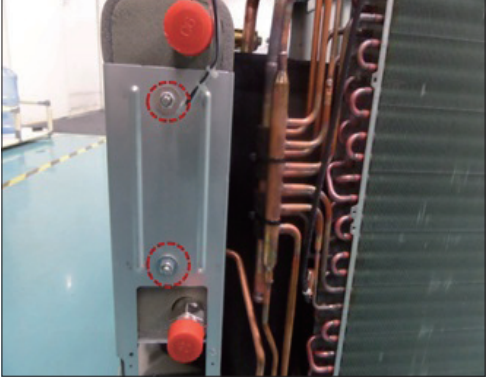

No	Parts	Procedure	Remark
9	CONTROL OUT	<p>1) Disconnect the six connectors from the ASSY CONTROL OUT.</p> <p>2) Unscrew and remove the two screws on the CONTROL OUT. (Use '+' type screw driver)</p> <p>3) Separate the ASSY CONTROL OUT</p>	

No	Parts	Procedure	Remark
10	ASSY-VALVE 4WAY	1) Purge the coolant first. 2) Separate the pipe from the Entrance/Exit using a welder.  ⚠ When removing the compressor, heat exchanger and pipe, purge the completely and remove the pipe with a welding flame.	
11	ASSY TUBE-WATER	1) Purge the coolant first.	

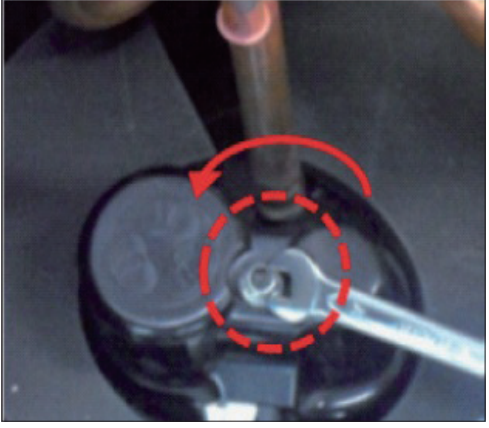
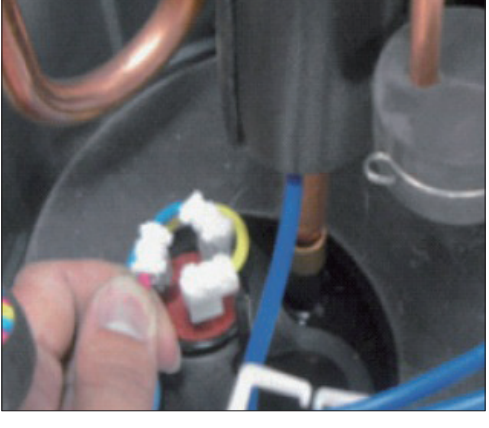

No	Parts	Procedure	Remark
		2) Turn the two nuts as shown in the picture and remove them. (Use adjustable wrench)	
12	ASSY BRACKET PHE	1) Unscrew and remove the 4 screws on the ASSY BRACKET PHE. (Use '+' type screw driver)	

No	Parts	Procedure	Remark
13	COMPRESSOR	<p>1) Separate the COMPRESSOR FELT SOUND.</p> <p>2) Unscrew and remove the nut on the COVER TERMINAL. (Use adjustable wrench)</p> <p>3) Separate the compressor wire.</p> <p>4) Separate the COMPRESSOR FELT SOUND.</p>	   

No	Parts	Procedure	Remark
		<p>5) As shown in the picture, unscrew and bottom. (Use Adjustable Wrench)</p>	
<p>14</p>	<p>ASSY COND OUT</p>	<p>1) Unscrew and remove the four screws as shown in the picture. (Use '+' type screw driver)</p>	

## 4. Troubleshooting

### 4-1 Wired remote controller

- Press the Test button to see the error code.

Error mode	Contents	Measure	Product operation in error condition	Error type
			Outdoor unit/ Compressor/Control Kit	
101	Control Kit communication error	Check the communication cable of Control Kit. Check the DC output voltage at the communication terminal	Operation Off	Communication error
108	Control Kit address setting error	Check address setting of Control Kits	Operation Off	Communication error
109	Control Kit communication error	Check Control Kits quantity setting in outdoor unit. Check electrical connection and setting	Operation Off	Communication error
121	Indoor temperature sensor (open/short error)	Check Control Kit room sensor location	Operation Off	Indoor sensor error
122	Control Kit Eva In sensor (Open/Short)	Check Control Kit Eva in sensor location	Operation Off	Indoor sensor error
123	Control Kit Eva Out sensor disconnection	Check Control Kit Eva out sensor location	Operation Off	Indoor sensor error
162	EEPROM Error	Check EEPROM PBA	Operation Off	Communication error
198	Error of Terminal Block's Thermal fuse(OPEN)	Check the Control Kit PBA's power input Terminal block	Operation Off	Control Kit error
201	Hydro Unit quantity is mismatched	Hydro Unit quantity must be matched with outdoor unit 1 by 1. Check the Hydro Unit quantity. It must be 1EA.	Operation Off	Communication error
202	Indoor/outdoor communication error (1 min)	Check the communication connection between indoor and outdoor units. Check the power line and communication cable connection status	Operation Off	Communication error
203	Communication error between indoor/outdoor INV↔MAIN MICOM (1 min)	Check MAIN MICOM Check INVERTER MICOM	-	Communication error
221	Outdoor temperature sensor error	Check sensor connection status Check sensor location Check sensor resistance	Operation Off	Outdoor sensor error
231	COND temperature sensor error	Check sensor connection status Check sensor location Check sensor resistance	Operation Off	Outdoor sensor error
251	[Inverter] Emission temperature sensor error	Check sensor connection status Check sensor location Check sensor resistance	Operation Off	Outdoor sensor error
320	OLP sensor error	Check outdoor unit OLP sensor location	Operation Off	Outdoor sensor error
403	Detection of outdoor freezing when Comp stop	Check outdoor cond	Operation Off	Comp down error
404	Protection of outdoor overload when Comp stop	Check outdoor comp	Operation Off	Comp down error
407	High Pressure switch error	Check refrigerant pipe line blockage. Check high pressure sensor. Check refrigerant amount.	Operation Off	Comp down error
416	Emission temperature excessively high	No error (DISCHARGE temperature control)	-	Outdoor unit protection control error
419	Outdoor EEV open error	Check the EEV of Outdoor. Check the EEV connector to the PCB.	Operation Off	Comp down error
422	Outdoor EEV close error	Check the EEV of Outdoor. Check the EEV connector to the PCB. Check the service valve.	Operation Off	Comp down error

## Wired remote controller (cont.)

Error mode	Contents	Measure	Product operation in error condition	Error type
			Outdoor unit/ Compressor/Control Kit	
425	3Phase power source miss wiring error	Check the 3-phase inspection part power of the outdoor unit PCB.	Operation Off	Self diagnostic error
439	Gas leakage error(Stop state)	Check Refrigerant leakage and shortage. Check Disconnection or breakdown of high & low pressure sensor.	Operation Off /	Comp down error
443	Gas leakage error (before operating)	Check Refrigerant leakage and shortage. Check Disconnection or breakdown of high pressure sensor.	Operation Off	Comp down error
440	Heating operation blocked	Check the operation setting state Check temperature sensor	Operation Off	Self diagnostic error
441	Cooling operation blocked	Check the operation setting state Check temperature sensor	Operation Off	Self diagnostic error
458	Outdoor fan 1 error	Check input power connection status Check the connection status between the motor and outdoor unit PCB Check indoor/outdoor fuse	Operation Off	Self diagnostic error
461	[Inverter] Compressor startup error	Check the compressor connection status Check the resistance between difference phases of the compressor	Operation Off	Outdoor unit protection control error
462	[Inverter] Total current error/ PFC over current error	Check the input power Check the coolant charging status Check the normal operation of outdoor fan	Operation Off	Outdoor unit protection control error
463	OLP over heat and comp stop	Check OLP sensor	Operation Off	Self diagnostic error
464	[Inverter] IPM over current error	Check coolant charging Check the compressor connection status and normal operation Check the obstacles around the indoor and outdoor units Check whether the outdoor unit service valve is open Check whether the indoor/outdoor installation pipe/ wiring are correct	Operation Off	Outdoor unit protection control error
465	Compressor V limit error	Check the compressor connection status Check the resistance between difference phases of the compressor	Operation Off	Outdoor unit protection control error
466	DC LINK over/low voltage error	Check input power Check AC power connection	Restart in 3 minutes	Outdoor unit protection control error
467	[Inverter] Compressor rotation error	Check the compressor connection status Check the resistance between difference phases of the compressor	Operation Off	Outdoor unit protection control error
468	[Inverter] Current sensor error	Check EEPROM DATA Check the normal operation of PCB	Operation Off	Outdoor unit protection control error
469	[Inverter] DC LINK voltage sensor error	Check the input power connection Check the status of RY21 and R200 in the INVERTER PCB	Operation Off	Outdoor unit protection control error
470	Outdoor EEPROM data checksum error	Check EEPROM DATA loading	Operation Off	Restart disabled error
471	[Inverter] OTP error	Check EEPROM DATA Check the normal operation of PCB	Operation Off	Outdoor unit protection control error
475	Outdoor fan 2 error	Check the input power connection status Check the connection status of the motor and the outdoor unit PCB Check the indoor/outdoor unit fuse	Operation Off	Self diagnostic error



## Wired remote controller (cont.)

Error mode	Contents	Measure	Product operation in error condition	Error type
			Outdoor unit/Compressor/Control Kit	
484	PFC overload error	Check reactor located in control plate. If reactor is normal, exchange INVERTER PBA.	Operation Off	Comp down error
485	Input current sensor error	Check Input current sensor on Inverter PCB	Operation Off	Comp down error
500	IPM is over heated	Check INVERTER PBA's temperature. Power off and cool down INVERTER PBA, and then restart the outdoor unit.	Operation Off	Comp down error
554	Gas leak error	Check the coolant charging status Check the indoor EVA sensor Check if the outdoor unit service valve is open Check that the indoor/outdoor installation pipe/wiring are correct	Operation Off	Self diagnostic error
556	Capacities not matched	Check the option code of the Control Kit	Operation Off	Outdoor unit protection control error
557	Option code miss matching among the indoors(only for DPM)	Option setting data is wrong. (This error don't occur in EMF 150-AM).	Operation Off	Comp down error
590	Inverter EEPROM loading error	Check EEPROM DATA. Check the normal operation of PCB.	Operation Off	Comp down error
601	Communication error between the Hydro Unit and wired remote controller	Check the Control Kit PBA and wired remote controller	Operation Off	communication error
604	Communication tracking error between the Hydro Unit and wired remote controller	Check the Control Kit PBA and wired remote controller	Operation Off	communication error
653	Wired remote controller temp sensor SHORT or OPEN	Check sensor connection status	Operation Off	wired remote controller sensor error
654	Memory(EEPROM) Read Write error(Wired remote controller data error)	Check the wired remote controller	Operation Off	communication error
901	Water inlet (PHE) temp sensor error (Short/Open)	Check sensor connection status. Check sensor location. Check sensor resistance.	Operation Off	Indoor sensor error
902	Water outlet (PHE) temp sensor error (Short/Open)	Check sensor connection status. Check sensor location. Check sensor resistance.	Operation Off	Indoor sensor error
904	Water tank temp sensor error (Short/Open)	Check sensor connection status. Check sensor location. Check sensor resistance.	Operation Off	Indoor sensor error
906	Refrigerant gas inlet temp sensor error (Short/Open)	Check sensor connection status. Check sensor location. Check sensor resistance.	Operation Off	Indoor sensor error
911	Flow switch open error	Check the junction point of Flow Switch terminal. Check the junction point signal of Paddle operation after the Flow Switch disassembly. Check the water flow(Strainer clogging, Pump operation)	Operation Off	Comp down error
912	Flow switch close error	Check the junction point of Flow Switch terminal. Check the junction point signal of Paddle operation after the Flow Switch disassembly. Check the water flow(Strainer clogging, Pump operation)	Operation Off	Comp down error
914	Thermostat wrong connection error	Check the wiring of Hydro Unit Thermostat. Check the Cooling /Heating signal : Concurrent wiring or not.	Operation Off	Indoor sensor error
916	Mixing valve temp sensor error (Short/Open)	Check Control Kit Mixing Valve Outlet temperature sensor location.	Operation Off	Indoor sensor error

## 4-2 Troubleshooting by symptoms

### 4-2-1 Communication error after finishing Tracking

Indoor unit display	E604
Symptom	Communication error between the Control Kit and outdoor unit for two minutes
Failure	Communication error between the Control Kit and outdoor unit

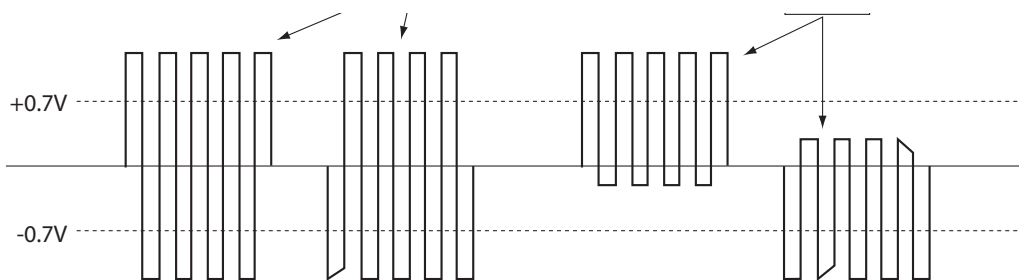
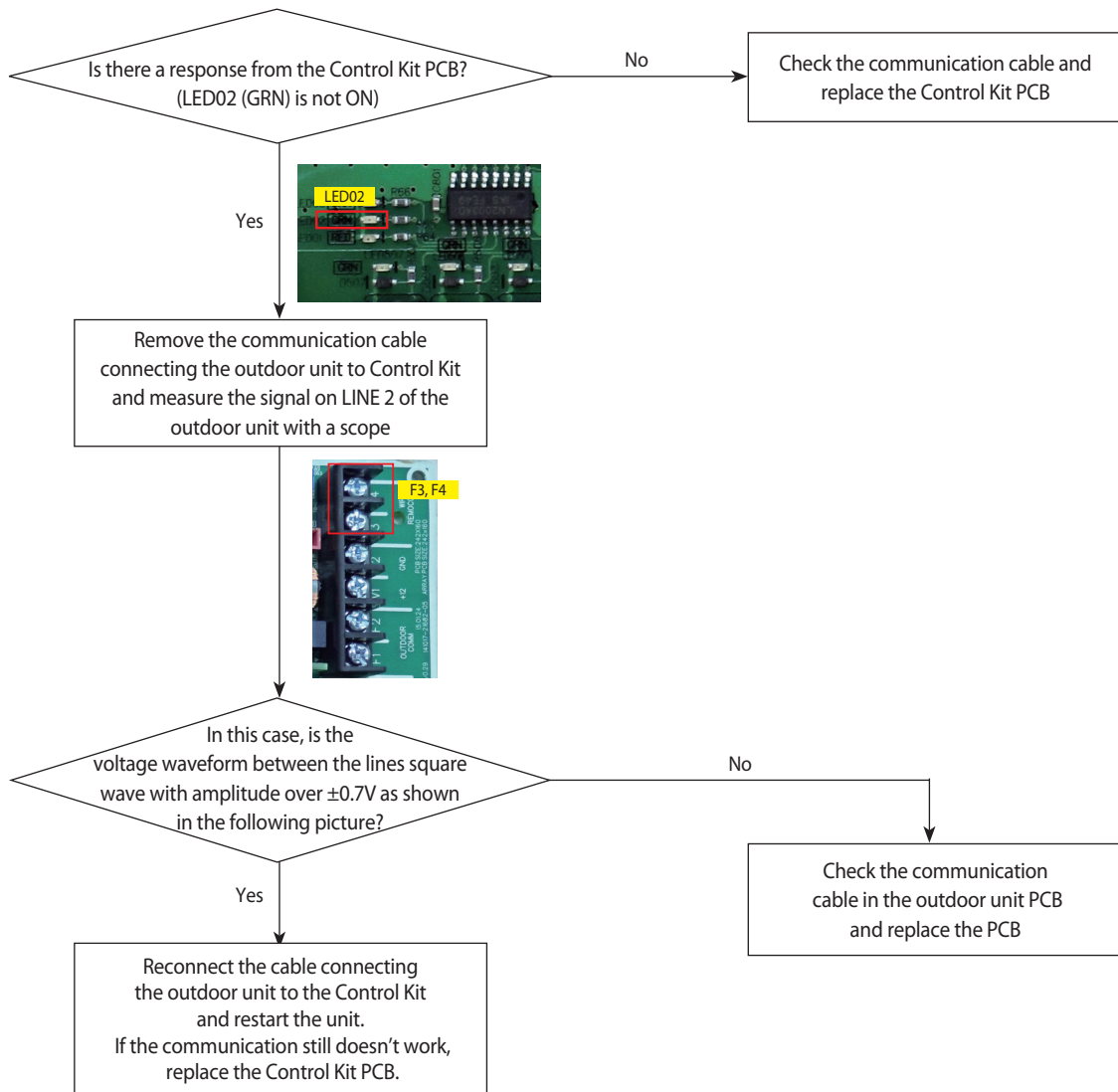

## 4-3 Control Kit

### 4-3-1 EEPROM error

Outdoor unit display	<i>E 162</i>
Indoor unit display	×(Operation) ●(Timer) ●(Fan) ●(Filter) ×(Defrost)
Criteria	• Communication failure between EEPROM and MICOM
Cause of problem	• PCB replacement due to defective EEPROM

#### 1. How to check

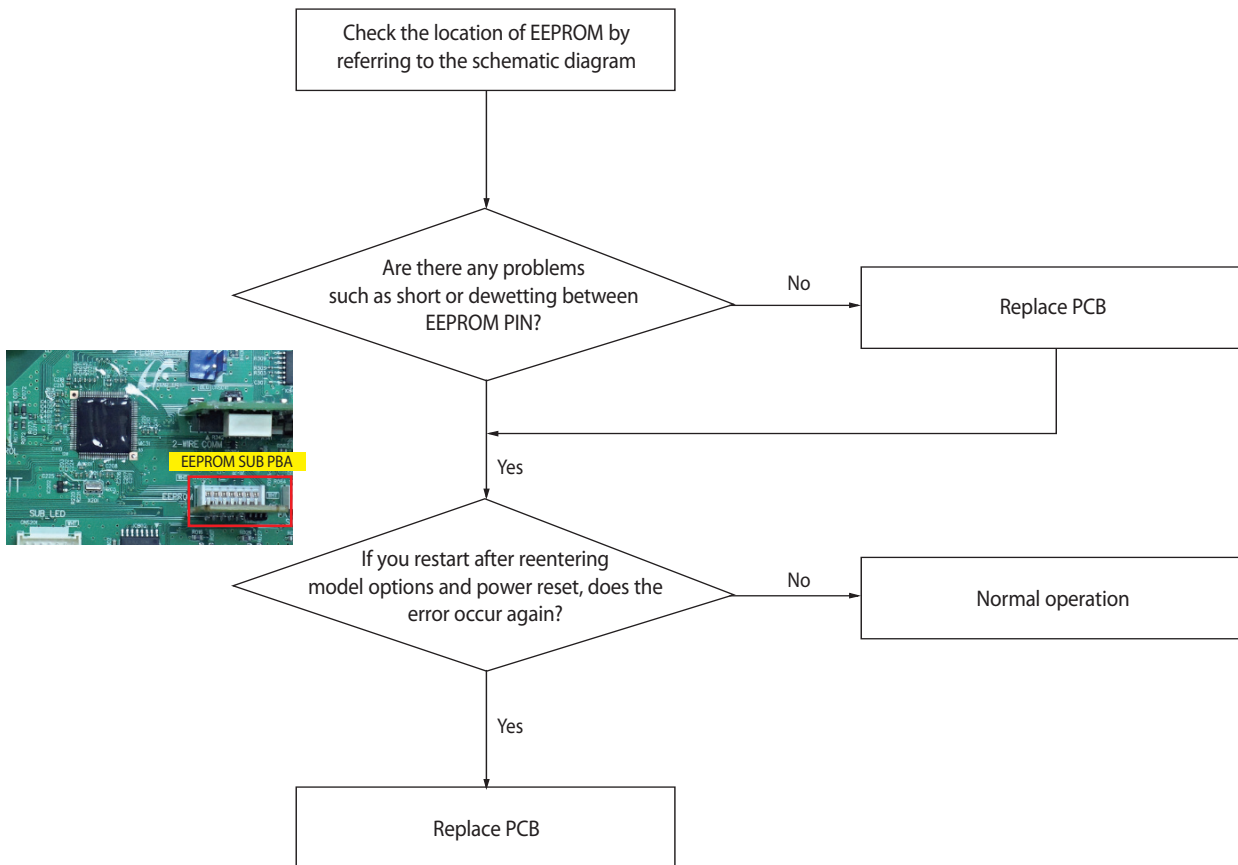



### 4-3-2 E653: Error due to abnormal data of Wired remote controller thermistor value

Outdoor unit display	E653 ↔ A <sup>x</sup> x <sup>x</sup> (x x x: The address of the error occurred indoor unit)
Wired remote display	E653
Criteria	• Refer to how to determine below
Cause of problem	• Wired remote room thermistor has a defective OPEN/SHORT

1. How to check

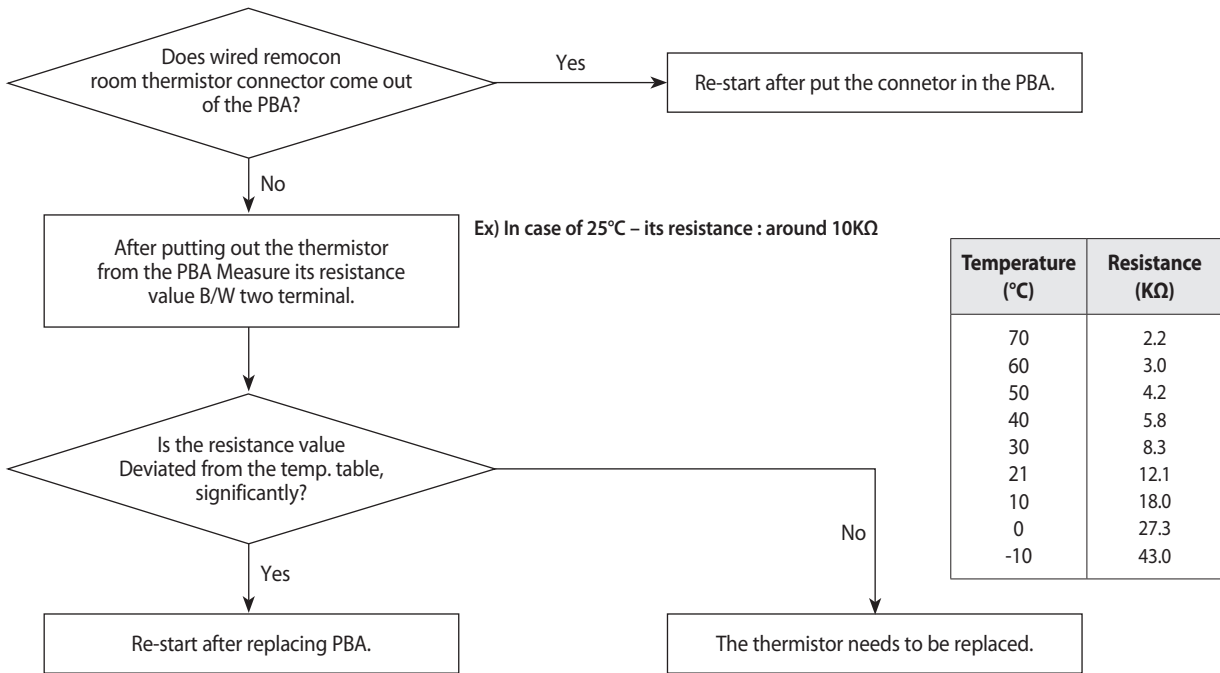

### 4-3-3 Water pump & flow switch OFF

Wired remote display	<b>E911</b>
Criteria	• Refer to how to determine below
Cause of problem	• Flow S/W OFF in 30 sec during water pump signal is ON(Starting) • Flow S/W OFF in 15 sec during water pump signal is ON (After starting)

1. How to check

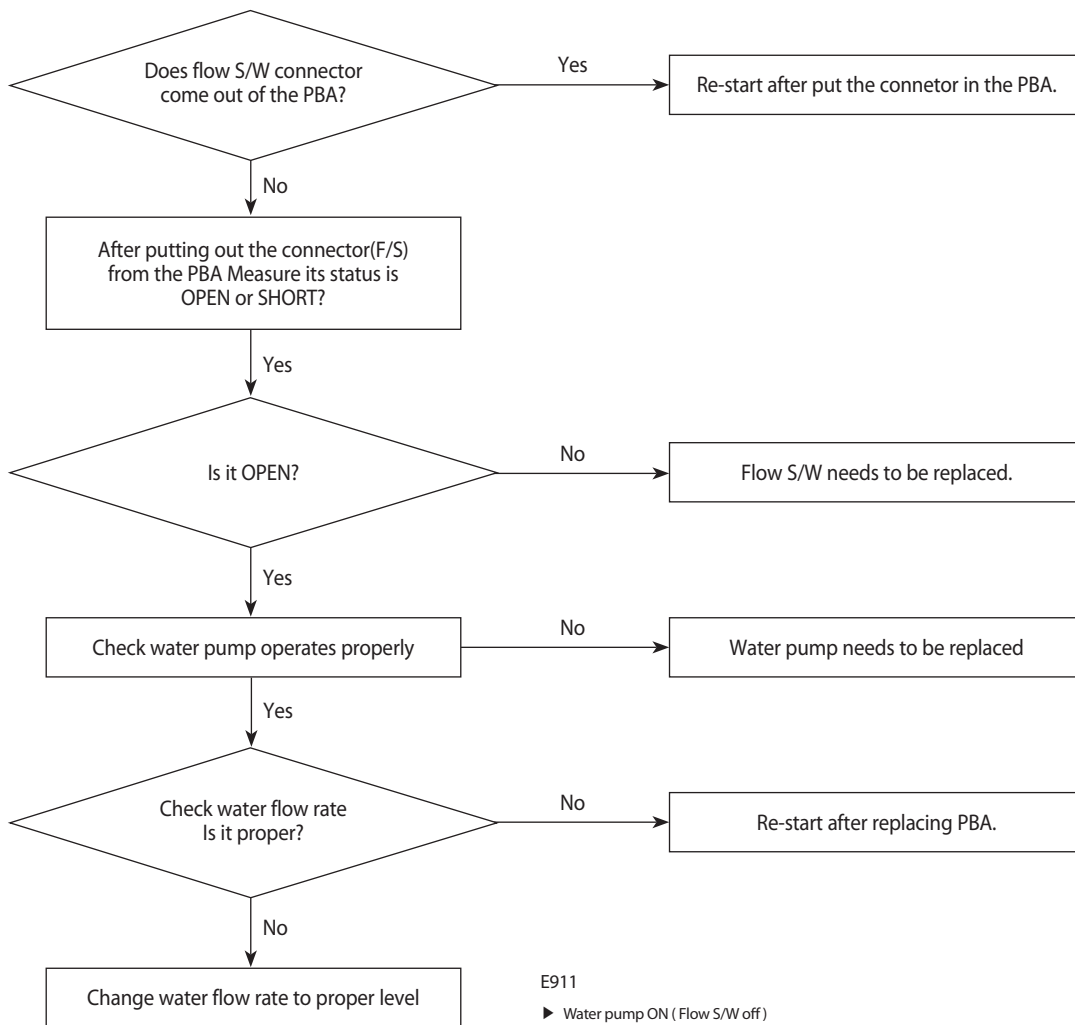

E911

▶ Water pump ON ( Flow S/W off)

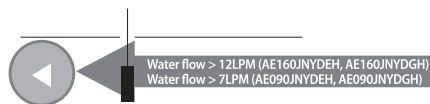

▶ Water pump ON ( Flow S/W off) : NOT enough water flow

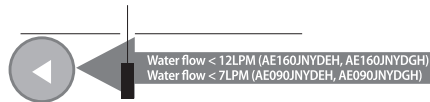

### 4-3-4 Water pump & flow switch ON

Wired remote display	<b>E9 12</b>
Criteria	• Refer to how to determine below
Cause of problem	• Flow S/W ON in 10minutes during water pump signal is OFF.

1. How to check

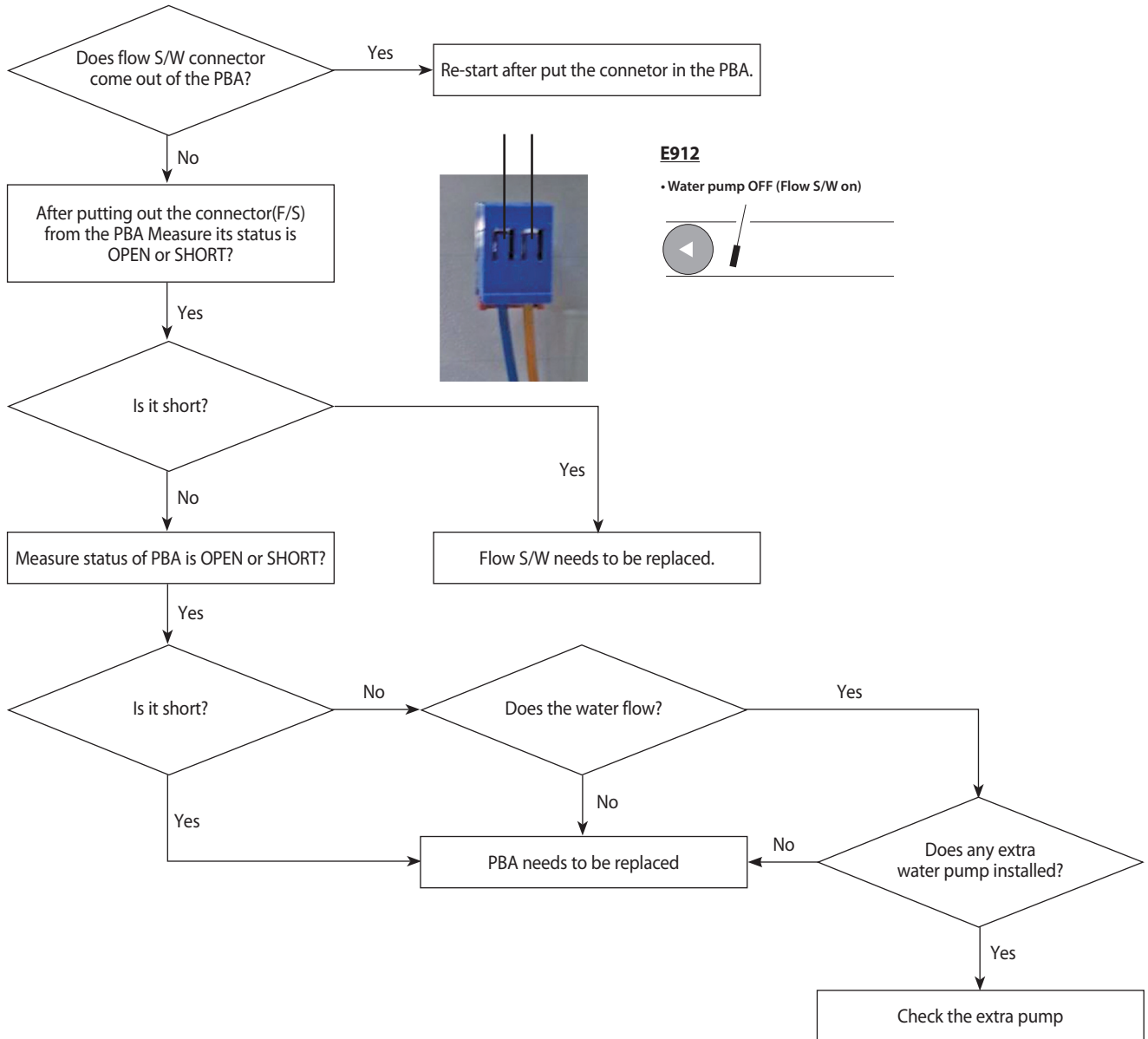

### 4-3-5 Control Kit temperature sensor(open/short)

<b>Error Mode</b>	E121,E122,E123, E901, E902, E903, E904, E906, E916
<b>Symptom</b>	In case of open or short circuit of indoor temperature sensor
<b>Failure</b>	Short or leakage of the corresponding sensor

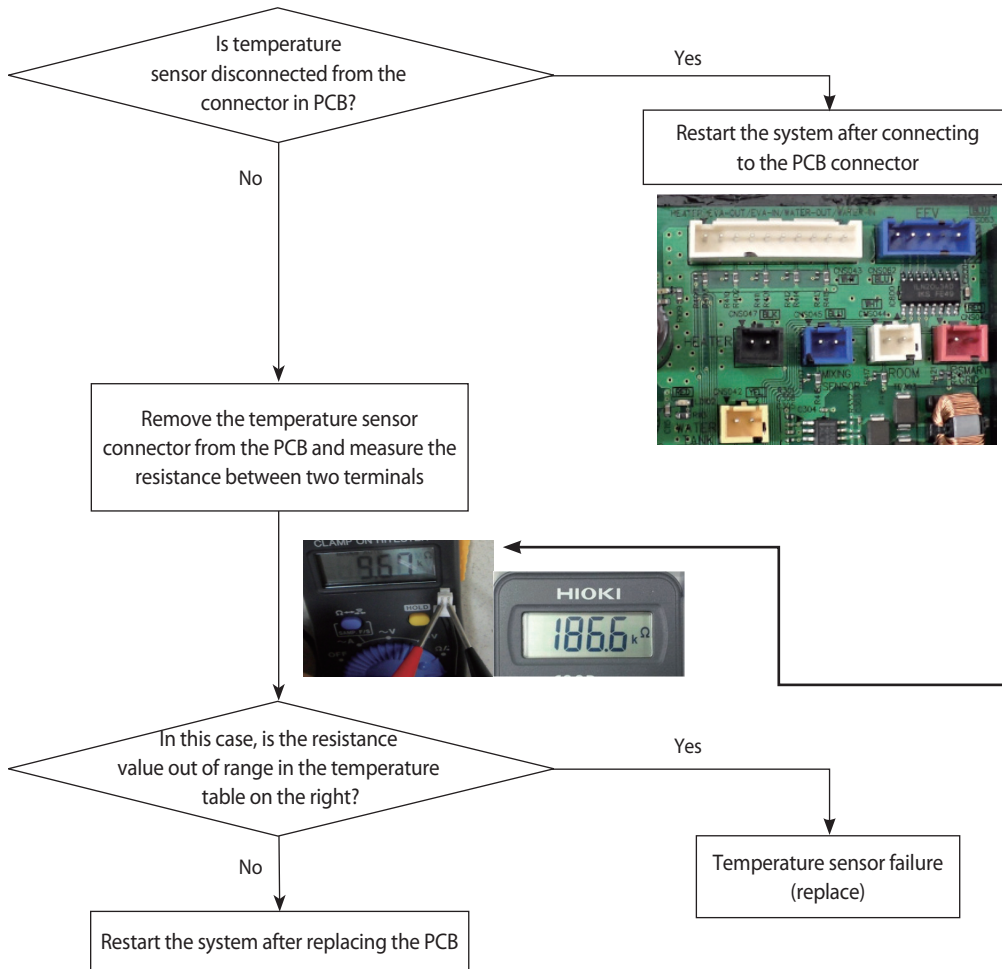

**<204 Type>**

Current temperature (°C)	Resistance (kΩ)
60	59.16
55	69.44
50	81.92
45	96.95
40	115.4
35	137.8
30	165.7
25	200
20	242.5
15	295.4
10	362.4

**<103 Type>**

Current temperature (°C)	Resistance (kΩ)
60	3.03
55	3.59
50	4.17
45	4.93
40	5.84
35	6.95
30	8.32
25	10
20	12.08
15	14.68
10	17.94

Error Mode	Sensor Type
E121,E122,E123, E901,E902,E903, E906,E916	103
E904	204

### 4-3-6 Communication error after finishing Tracking(Hydro unit)

<b>Error Mode</b>	E201, E202
<b>Symptom</b>	Communication error between the Hydro unit and outdoor unit for two minutes
<b>Failure</b>	Communication error between the Hydro unit unit and outdoor unit

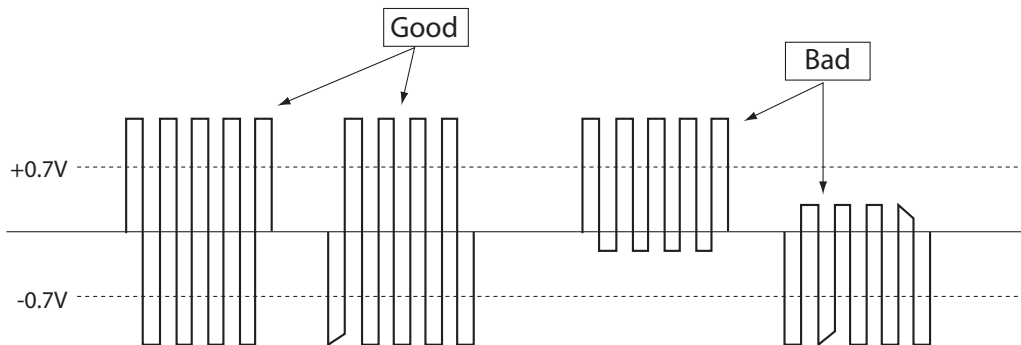
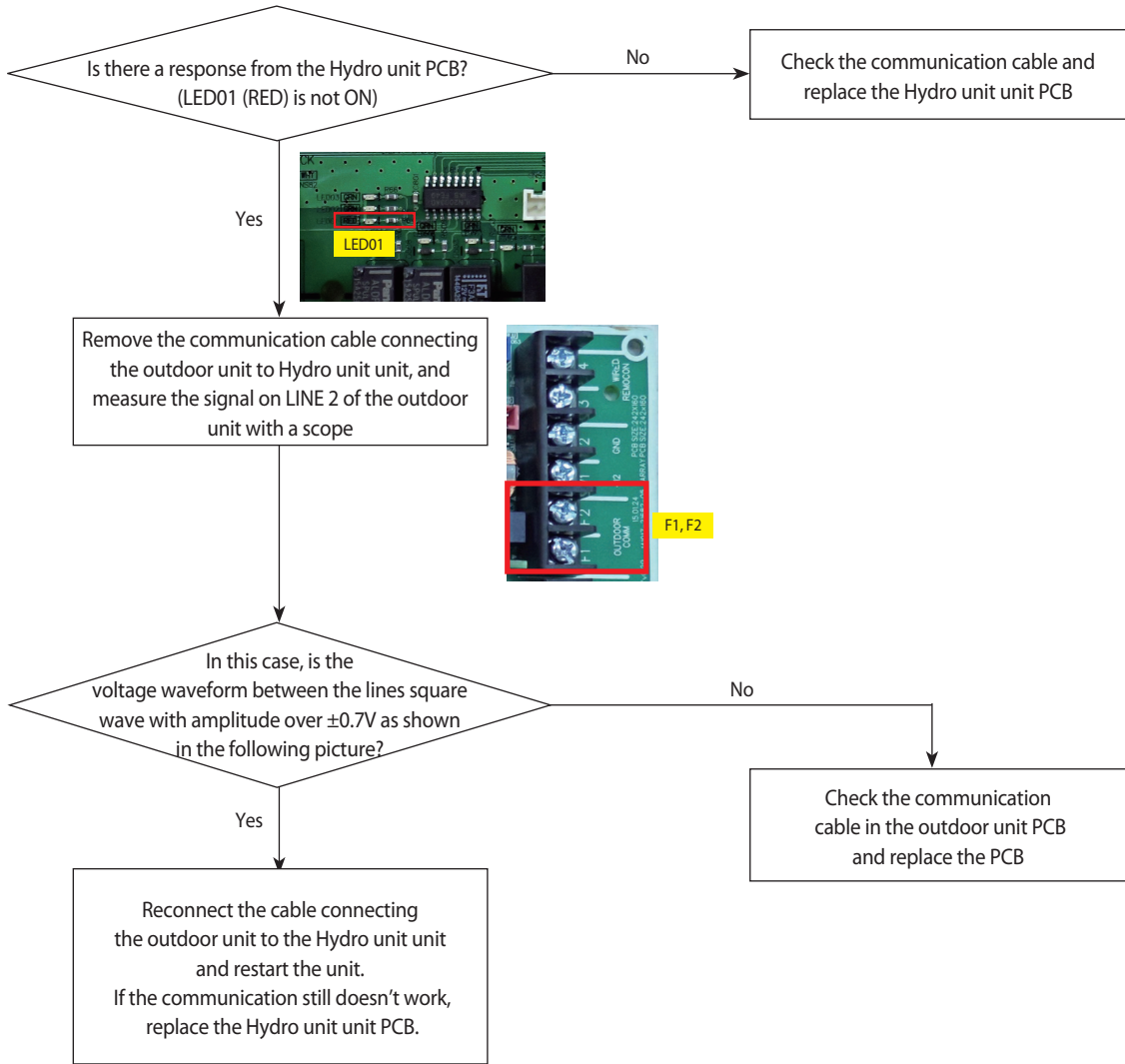

## 4-4 Items to check before diagnostics

### 4-4-1 Test run mode and view mode

#### Display Option Key

KEY	KEY operation	7-segment display
K1	Press once : Heating test run	"H" "1" "BLANK" "BLANK"
	Press twice : Defrost test run	"H" "3" "BLANK" "BLANK"
	Press 3times : Finishing test mode	-
K2	Press once : Cooling test run (Heating Only : skip)	"H" "2" "BLANK" "BLANK"
	Press twice : Output signal test run	"H" "4" "BLANK" "BLANK"
	Press 3 times : Finishing test mode	-
K3	Reset	-
K4	View mode	Refer to View mode display

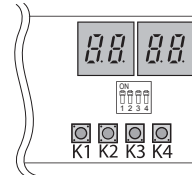

#### VIEW mode display

Number of press	Display contents	Display				Units
		Segment 1	Segment 2	Segment 3	Segment 4	
0	Communication State	10s digit of Tx	1s digit of Tx	10s digit of Rx	1s digit of Rx	-
1	Order frequency	1	100s digit	10s digit	1s digit	Hz
2	Current frequency	2	100s digit	10s digit	1s digit	Hz
3	Pump output	3	100s digit	10s digit	1s digit	%
4	Outdoor air sensor	4	+/-	10s digit	1s digit	°C
5	Discharge sensor	5	100s digit	10s digit	1s digit	°C
6	Eva in sensor (MONO)	6	+/-	10s digit	1s digit	°C
7	Inlet water sensor (MONO)	7	+/-	10s digit	1s digit	°C
8	Outlet water sensor (MONO)	8	+/-	10s digit	1s digit	°C
9	Cond sensor	9	+/-	10s digit	1s digit	°C
10	Current	A	10s digit	1s digit	First decimal	A
11	Fan RPM	B	1000s digit	100s digit	10s digit	rpm
12	Target discharge temperature	C	100s digit	10s digit	1s digit	°C
13	EEV	D	1000s digit	100s digit	10s digit	step
14	Protective control	E	0 : Cooling 1 : Heating	Protective control 0 : No protective control 1 : Freezing 2 : Defrosting 3 : Over-load 4 : Discharge 5 : Total current	Frequency status 0 : Normal 1 : Hold 2 : Down 3 : Up_limit 4 : Down_limit	-
15	IPM temp.	F	+/-	10s digit	1s digit	°C
long-1	Main Micom version	Year(Dec)	Month(Hex)	Day(two digit)	Day(One digit)	-
long-1 and 1	Inverter Micom version	Year(Hex)	Month(Hex)	Day(two digit)	Day(One digit)	-
long-1 and 2	EEPROM version	Year(Hex)	Month(Hex)	Day(two digit)	Day(One digit)	-

#### DIP Switch Settings

	ON (default)	OFF	Remark
1	Heat Pump.	Heating Only.	
2	Anti-stack snow mode OFF.	Anti-stack snow mode ON.	
3	Silence operation		
	3	4	Mode
	ON	ON	Silience mode Step 1
	ON	OFF	Silience mode Step 2
4	OFF	ON	Silience mode Step 3
	OFF	OFF	Silience mode Step 1

### 4-4-2 Troubleshooting for outdoor unit

If an error occurs during the operation, it is displayed on the outdoor unit PCB LED, both MAIN PCB and INVERTER PCB.

No.	LED Display			Displayed PCB Assy	Meaning	Remarks	Error Code
	Red	Green	Yellow				
-	●	◎	○	MAIN/INVERTER	Normal operation (MAIN : Control Kit↔ Outdoor : Green ON) (INVERTER : MAIN PCB↔ INVERTER PCB : Green ON)		-
1	●	◎	○	MAIN	Hydro unit quantity is mismatched.	Check Control Kit quantity setting in outdoor	E201
2	●	●	○	MAIN/INVERTER	Abnormal state, no communication between Control Kit and Outdoor Main PCB	Check electrical connection and setting	E202
	▮	○	○				
4	●	●	◎	MAIN/INVERTER	1min. Time out of communication error(Main↔ Inverter)	Check electrical connection and setting	E203
5	●	◎	○	MAIN	Outdoor temp sensor error	Check Outdoor sensor Open/Short	E221
6	●	◎	○	MAIN	Cond. temp sensor error	Check Cond. sensor Open/Short	E231
7	●	◎	○	MAIN	Discharge temp sensor error	Check Discharge sensor Open/Short	E251
8	●	◎	○	MAIN	OLP Sensor Error	Check OLP sensor Open/Short	E320
9	●	◎	○	MAIN	Detection of Outdoor Freezing when Comp. Stop	Check Outdoor Cond.	E403
10	●	◎	○	MAIN	Protection of Outdoor Overload when Comp. Stop	Check Comp. when it start	E404
11	●	◎	○	MAIN	Discharge temperature of a compressor in an outdoor unit is overheated.		E416
12	●	◎	○	MAIN	Outdoor EEV Open error	Check EEV	E419
13	●	◎	○	MAIN	Miss wiring error at 3Phase power source line (Only 3Phase Model)	Check Power Line-R,S,T,N	E425
14	●	◎	○	MAIN	Gas leakage error (Stop state)	Check Gas leak	E439
15	●	◎	○	MAIN	Heating operation is not available since the outdoor air temperature is over 35°C.	Heating	E440
					16	Cooling	E441
16	●	◎	○	MAIN	Gas leakage error (Before operating)	Check Gas leak	E443
17	○	○	●	MAIN/INVERTER	Outdoor unit BLDC Fan 1 or Fan 2 error	FAN1 error	E458
						19	E475
18	○	◎	○	MAIN/INVERTER	Comp. Starting error		E461
19	●	◎	○	MAIN	Primary Current Trip error		E462
20	●	◎	○	MAIN	Over current trip / PFC over current error	Check OLP sensor	E463
21	◎	○	○	MAIN/INVERTER	IPM(IGBT Module) Over Current(O.C)		E464
22	○	●	◎	MAIN/INVERTER	Comp. Over load error		E465
23	◎	●	○	MAIN/INVERTER	DC-Link voltage under/over error	Check AC Power or DC_Link voltage	E466

○ Off    ◎ Blink    ● On

## Troubleshooting for outdoor unit(con.)

If an error occurs during the operation, it is displayed on the outdoor unit PCB LED, both MAIN PCB and INVERTER PCB.

No.	LED Display			Displayed PCB Assy	Meaning	Remarks	Error Code
	Red	Green	Yellow				
24	●	○	●	MAIN/INVERTER	Comp. wire missing error	Check Comp. wire	E467
25	●	◎	◎	MAIN/INVERTER	Current sensor error	Check Outdoor Inverter PBA	E468
26	●	◎	○	MAIN	DC-Ling voltage Sensor error	Check Input voltage	E469
27	●	◎	○	MAIN	EEPROM read/write error	Check EEPROM	E470
28	●	◎	○	MAIN	Outdoor EEPROM error	Check Outdoor EEPROM date	E471
29	◎	◎	○	MAIN/INVERTER	IPM(IGBT Module) or PFCM Temperature sensor Error	Check Outdoor Inverter PBA	E474
30	●	◎	●	MAIN/INVERTER	PFC Overload Error	Check Outdoor Inverter PBA	E484
31	●	◎	○	MAIN	Input current sensor error		E485
32	◎	◎	○	MAIN/INVERTER	IPM is over heated.	Check Outdoor Inverter PBA	E500
33	●	◎	○	MAIN	GAS Leak error	Check Control Kit and outdoor unit model	E554
34	●	◎	○	MAIN	Water inlet temperature sensor error	Check Water inlet sensor	E901
35	●	◎	○	MAIN	Water outlet temperature sensor error	Check Water outlet sensor	E903
36	●	◎	○	MAIN	Refrigerant gas inlet temperature sensor error	Check Gas inlet sensor	E906
37	●	◎	○	MAIN	Mixing Valve Outlet temperature sensor error	Check Mixing Valve Outlet sensor	E916

○ Off    ◎ Blink    ● On



## 4-5 Troubleshooting by symptoms

### 4-5-1 Communication error after finishing tracking (E202)

1. Check items
  - 1) Is the communication cable short/open?
  - 2) Is there a response from the Hydro unit PCB?
2. Check procedure

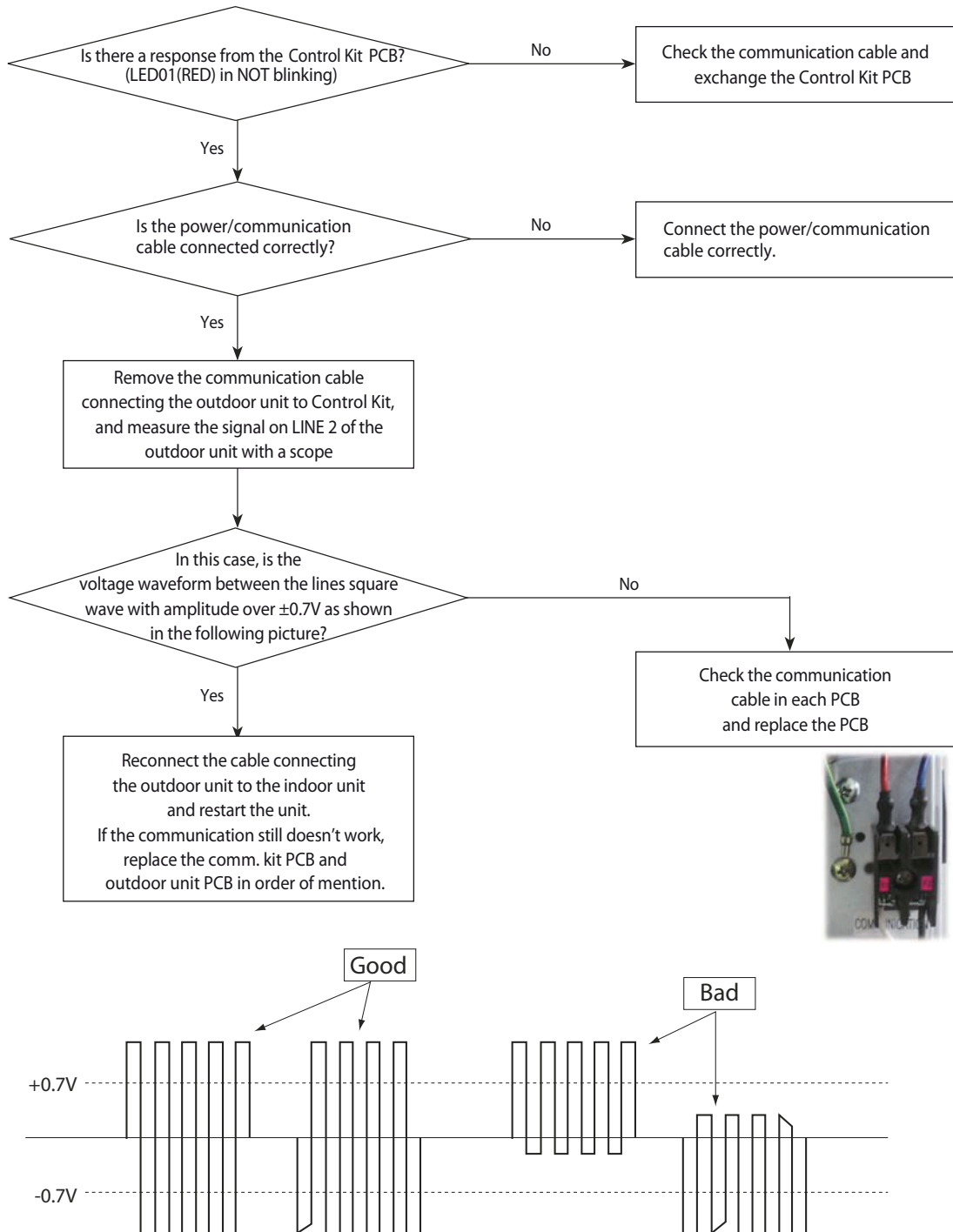

cf.) If there is no oscillo scope, it can be replaced multimeter instead of osillo scope.  
If measured voltage is floating value from 0.1V to 4.5V, then it means that the PCB is normal.

### 4-5-2 Time out (1 min.) of communication error between MAIN PBA and INV. PBA (E203)

1. Check items
  - 1) Is the communication cable connected properly between MAIN PBA and INVERTER PBA?
  - 2) Is the power cable connected correctly?
2. Check procedure

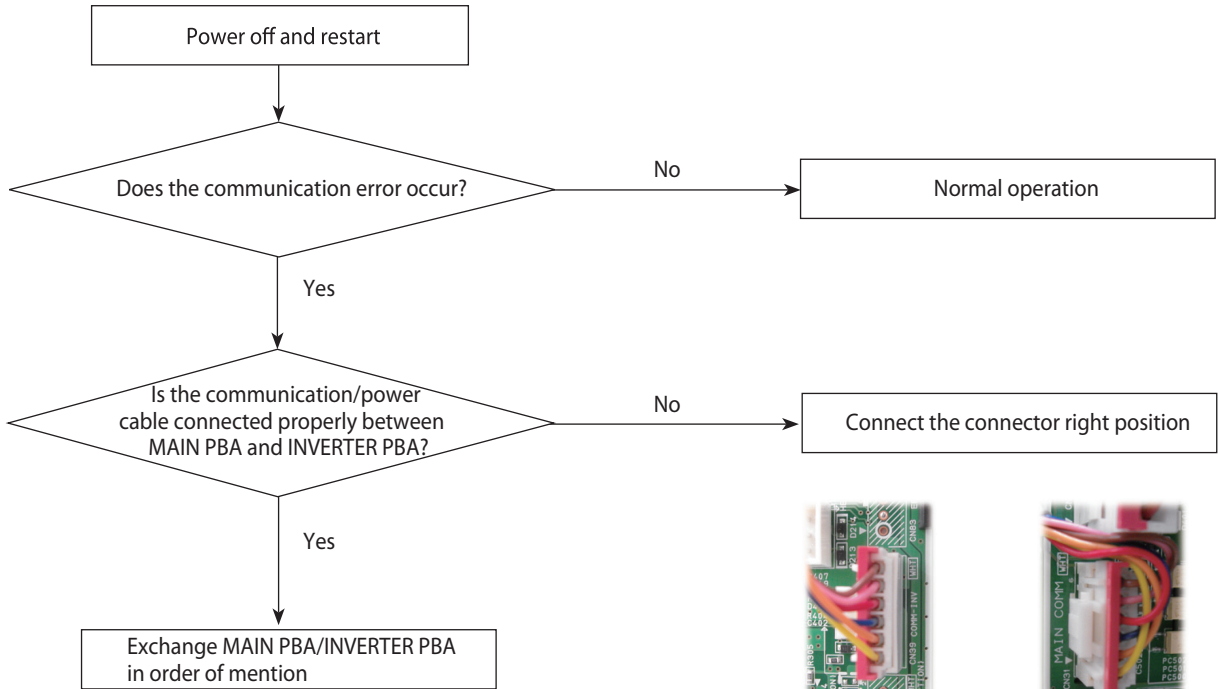

<CN305 in MAIN PBA > <CN31 in INVERTER PBA>

### 4-5-3 Temperature sensor error (E221, E231, E251, E320)

<Error code for each temperature sensor>

CN43 in MAIN PBA	Pin no.	Temp. sensor	Error code
	1,2	Outdoor	E221
	3,4	Condenser	E231
	5,6	Discharge	E251
	7,8	OLP	E320

1. Check items
  - 1) Is the sensor connected correctly (CN403 in MAIN PBA)?
  - 2) Is the position of sensor correct?
  - 3) Does the value of resistance satisfy the each temperature condition?

2. Check procedure

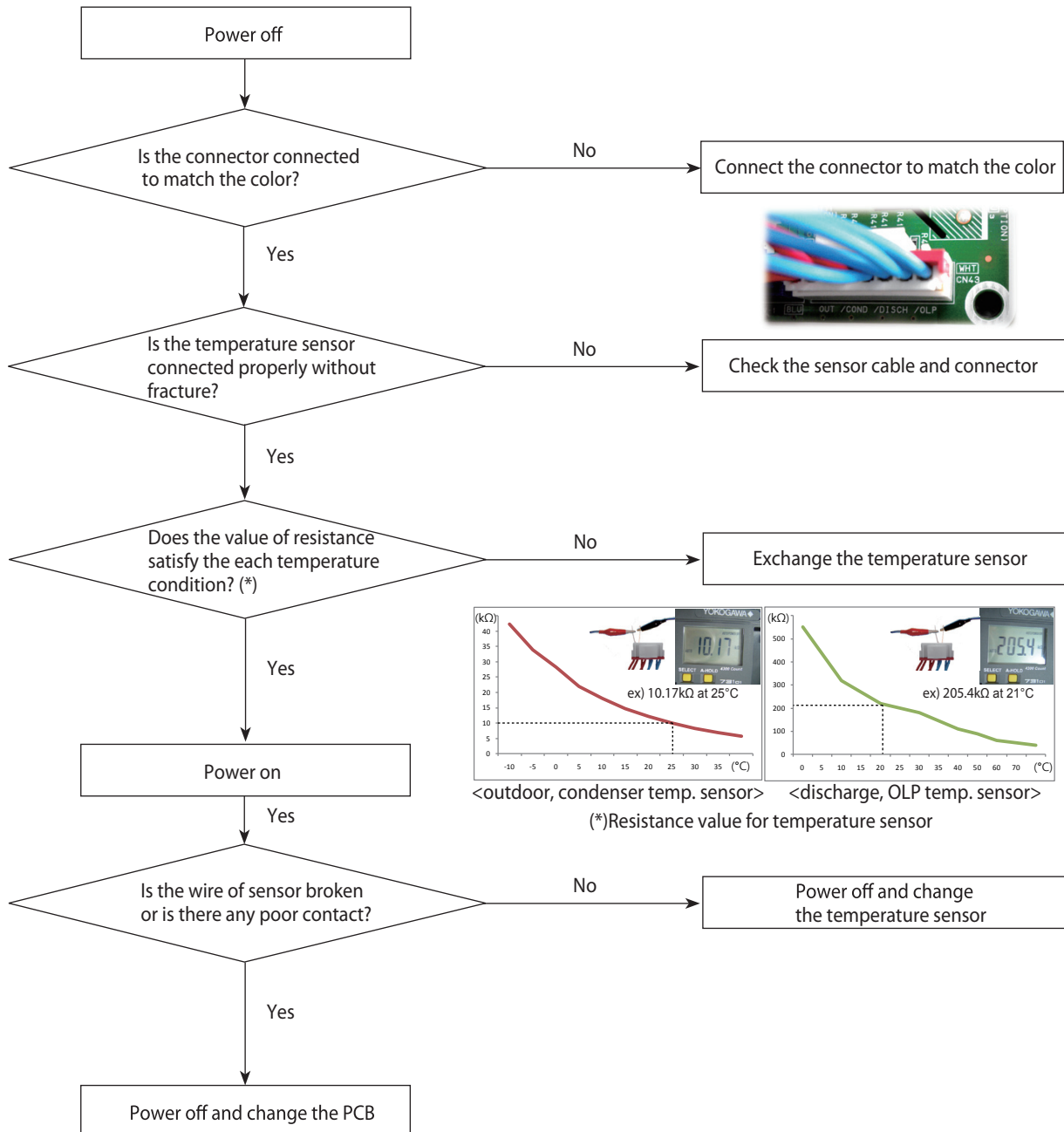

### 4-5-4 Fan error (E458, E475)

FAN 1 error(E458), FAN 2 error(E475)

1. Check items
  - 1) Are the input power voltage and power connection correct?
  - 2) Is the motor wire connected to the outdoor PCB correctly?
  - 3) Is there no obstacle at the surrounding of motor and propeller?
  - 4) Does the driver in the motor case broken?
2. Check procedure

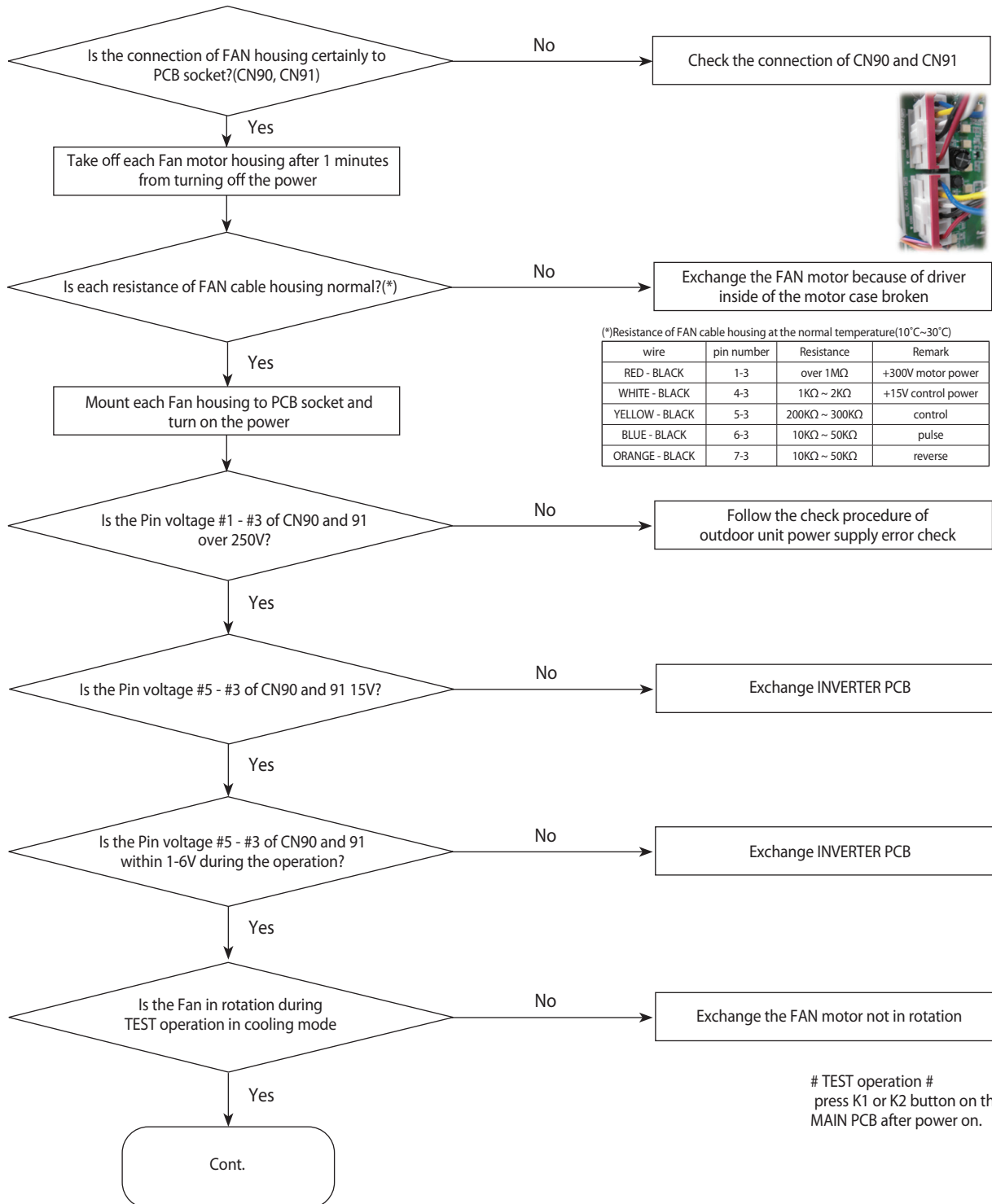

### Fan error (E458, E475) (cont.)

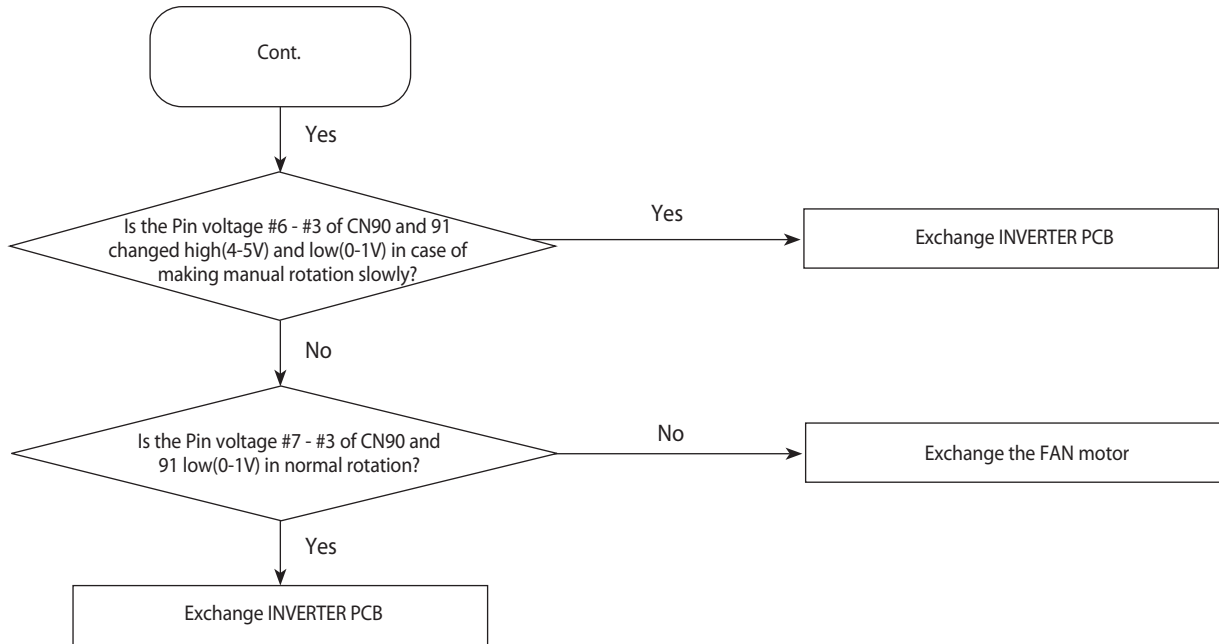

### 4-5-5 Compressor error (E461, E467)

Compressor starting error(E461), Compressor wire missing error(E467)

1. Check items
  - 1) Is the power connected properly?
  - 2) Is the connector of compressor connected correctly?
  - 3) Is the resistance normal between each phase for compressor ?
2. Check procedure

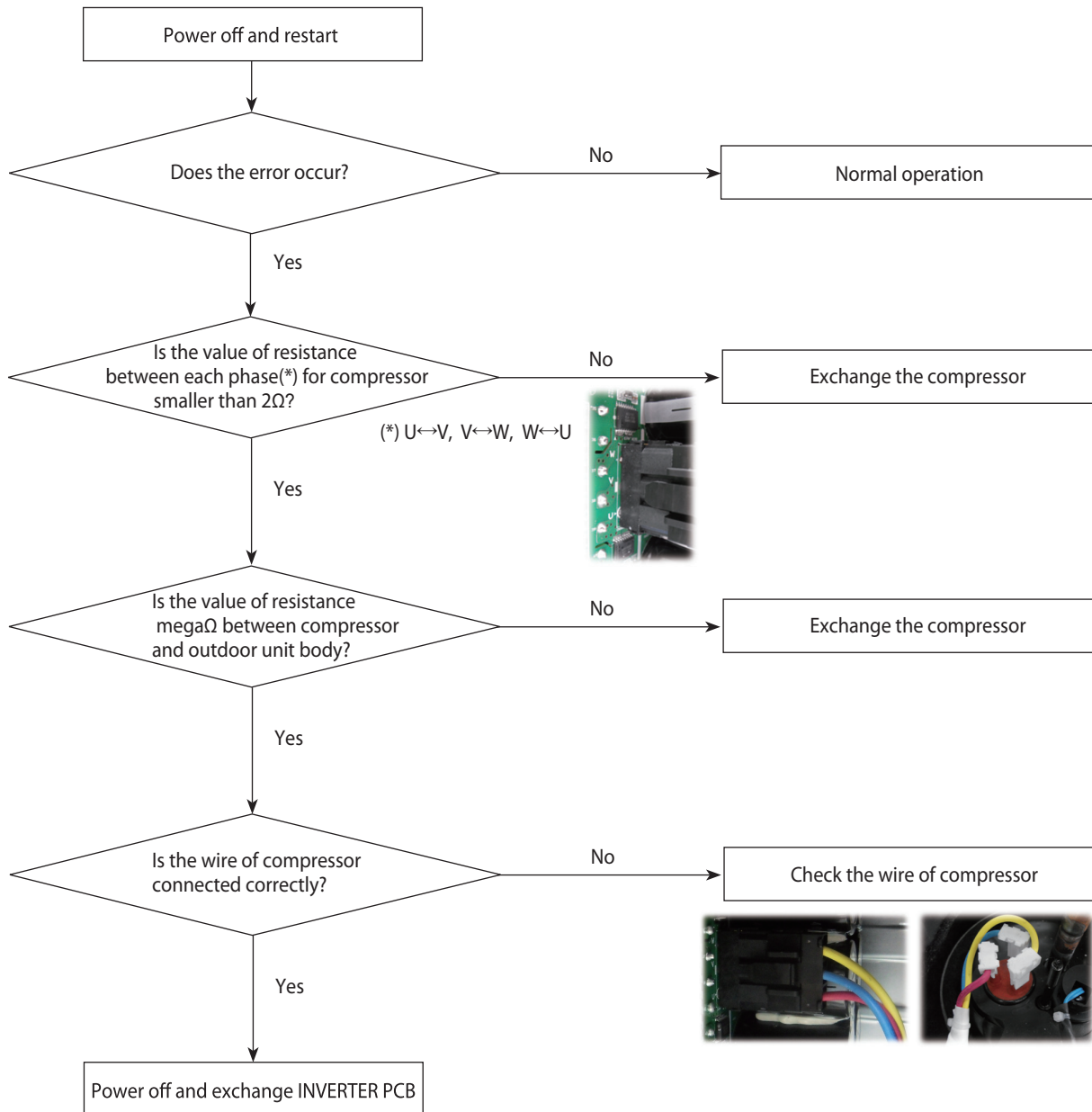

### 4-5-6 Current trip error (E462, E463)

Primary current trip error(E462), Over current trip / PFC over current error(E463)

1. Check items

- 1) Is the voltage of power suitable?
- 2) Is refrigerant charged?
- 3) Does the fan of outdoor unit work normally?
- 4) Is there any obstacle around indoor and outdoor unit?

2. Check procedure

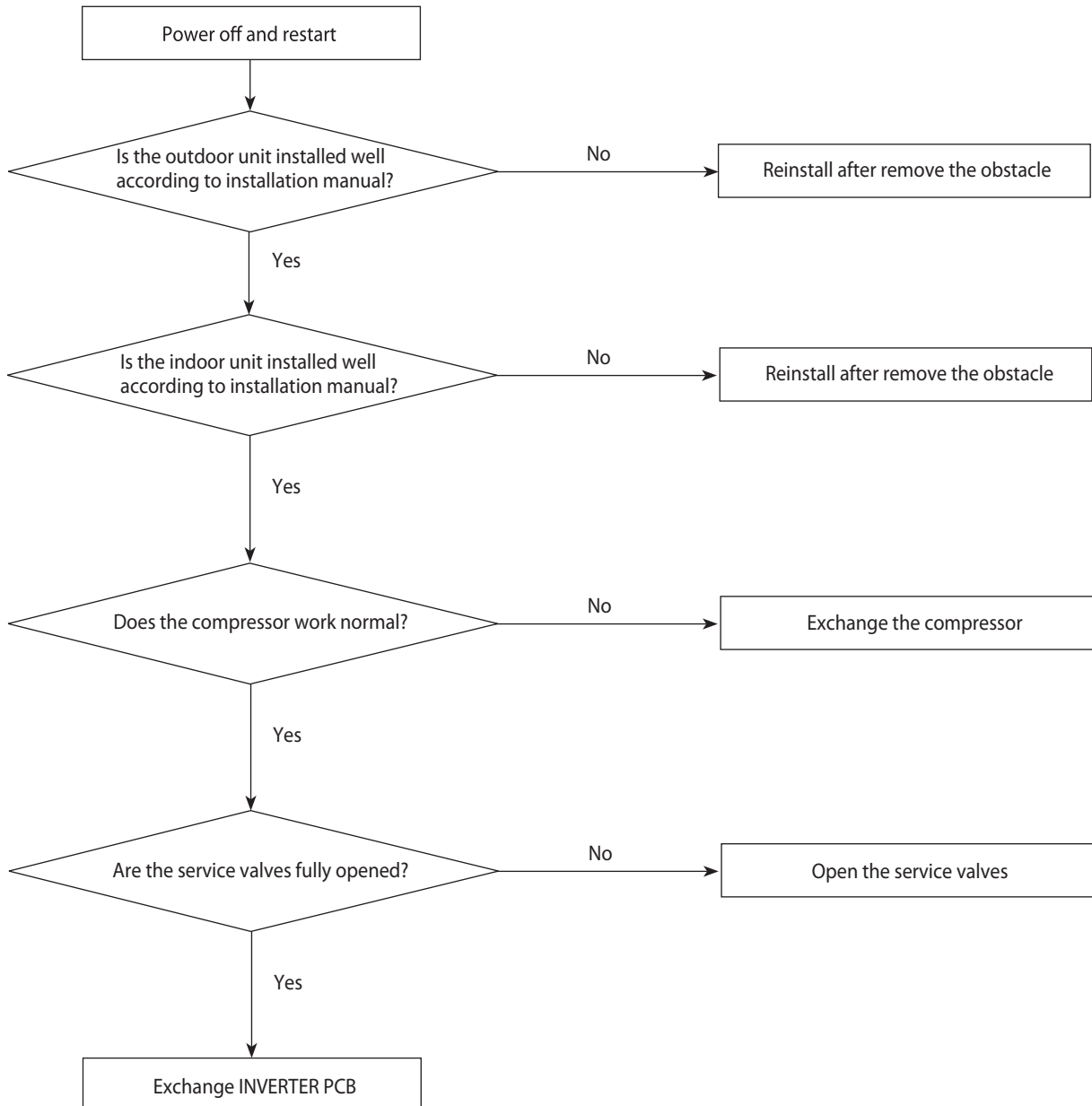

### 4-5-7 IPM(IGBT module) over current error (E464)

1. Check items

- 1) Is refrigerant charged?
- 2) Does the compressor work normally?
- 3) Is the connection of compressor correctly?
- 4) Is there any obstacle around indoor and outdoor unit?

2. Check procedure

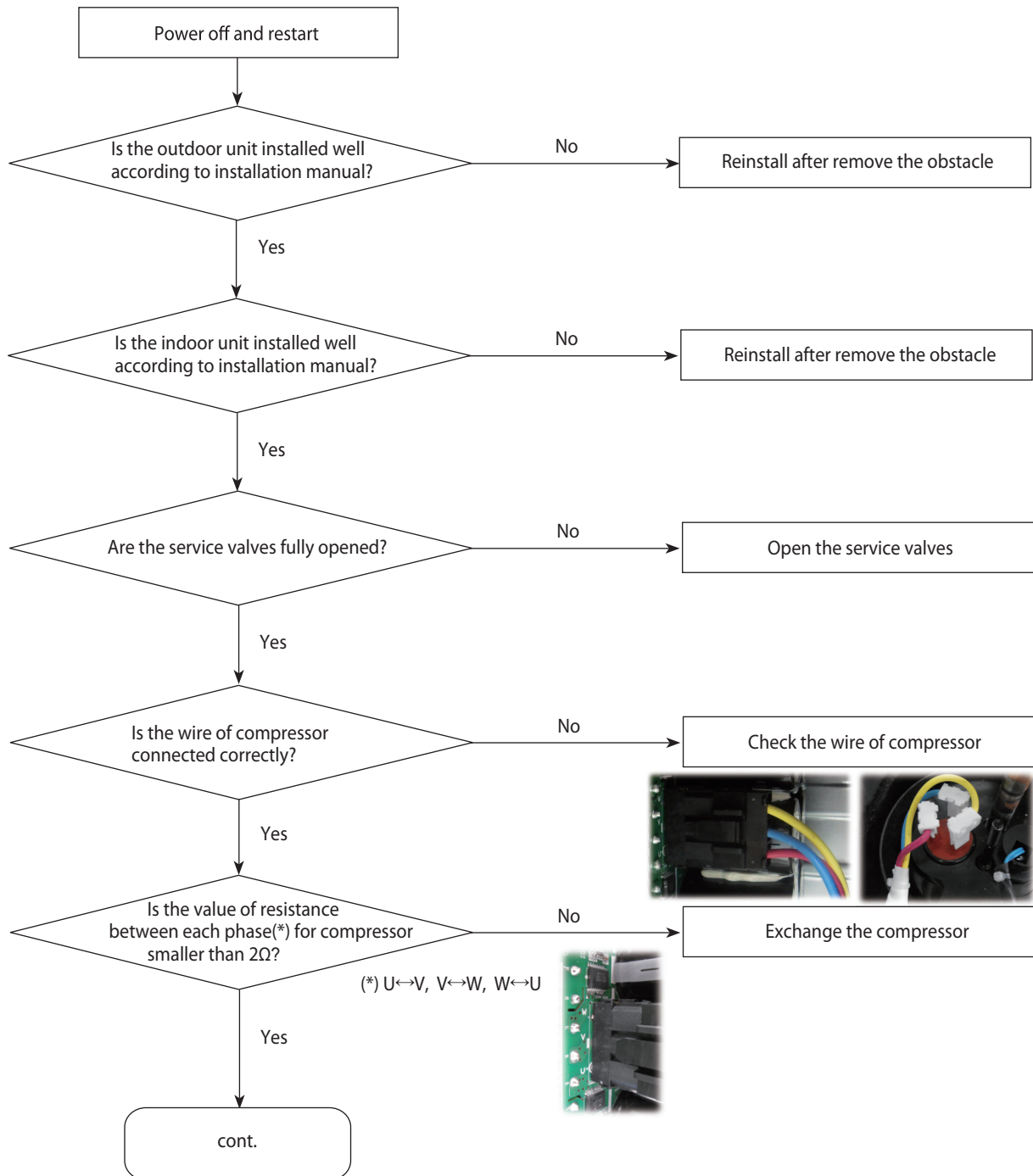



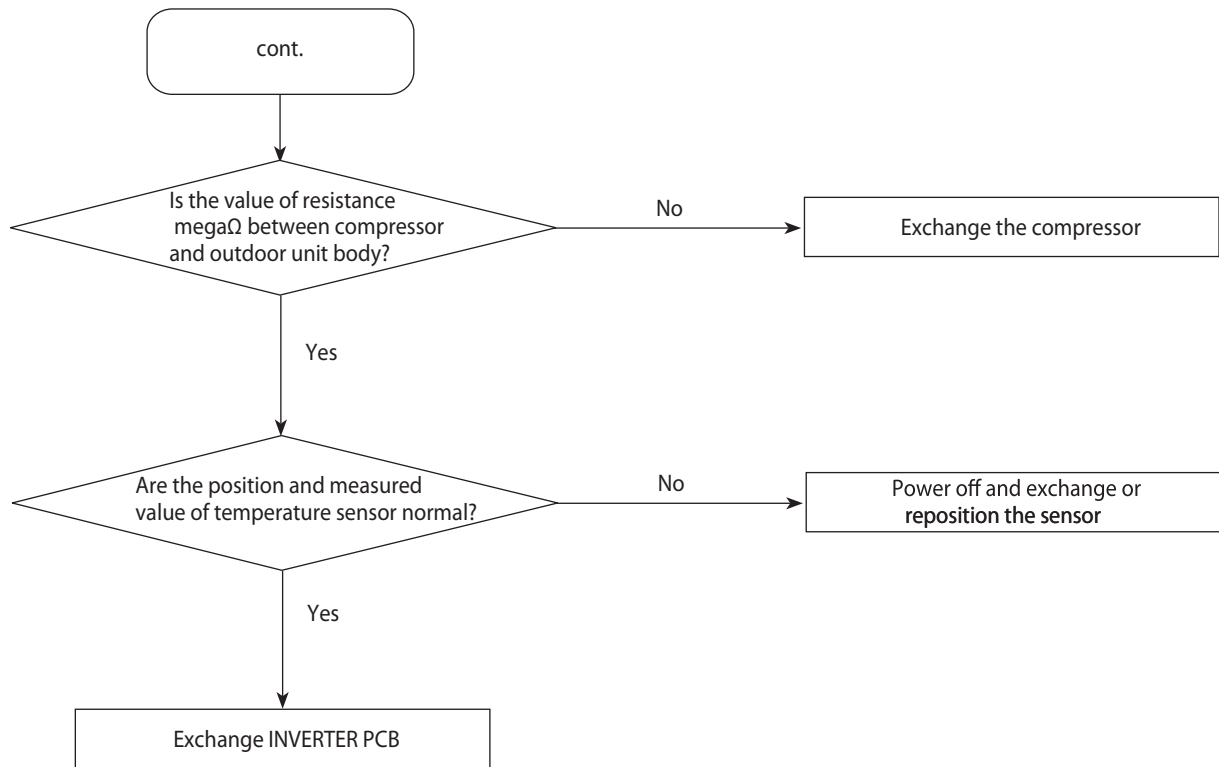

### 4-5-8 DC-link voltage under/over error (E466)

1. Check items
  - 1) Is the input power normal?
  - 2) Is the AC power connected correctly?
2. Check procedure

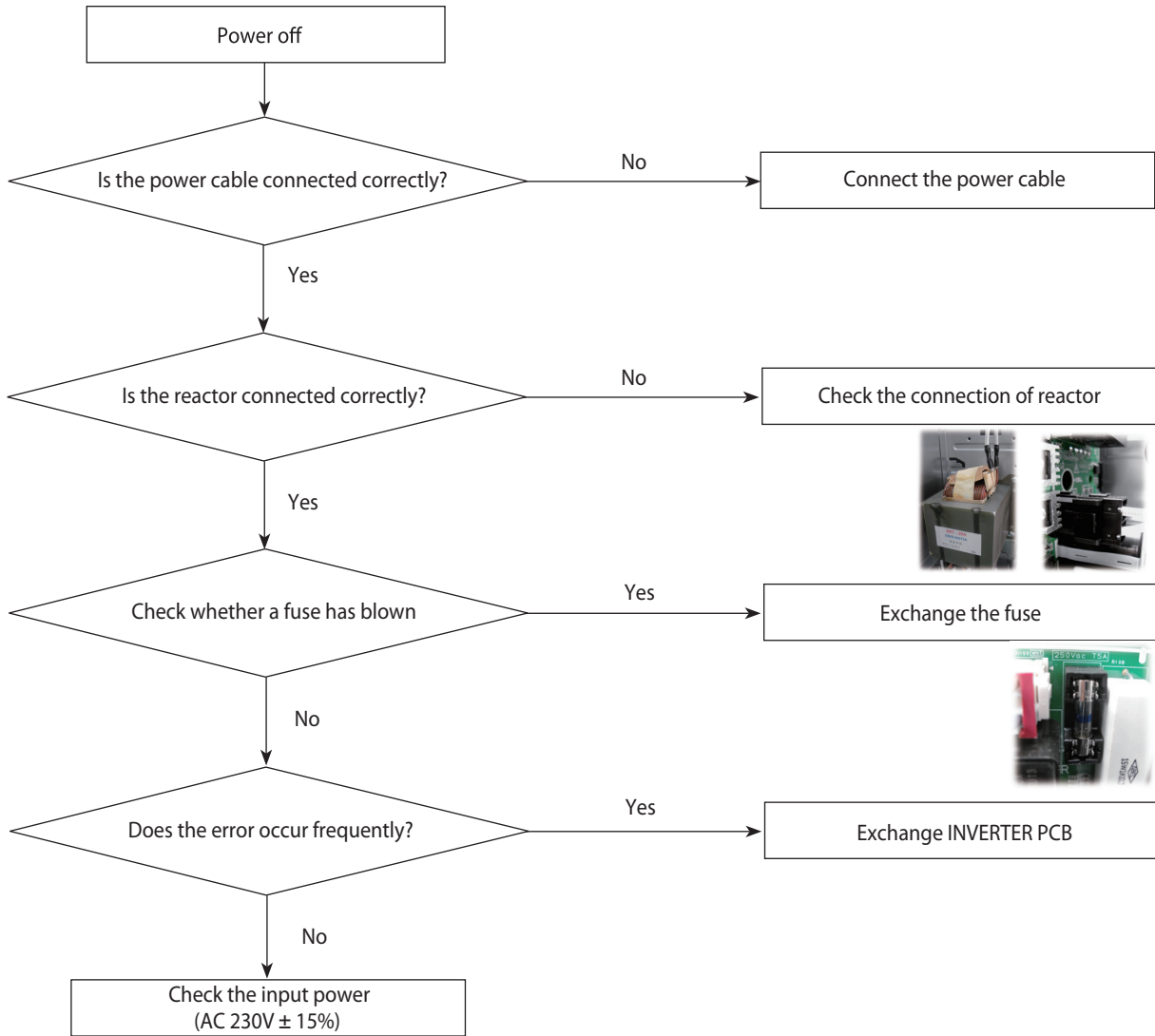

### 4-5-9 GAS leak error(E554)

1. Check items

- 1) Is refrigerant charged?
- 2) Is the evaporator sensor of indoor unit connected correctly?

2. Check procedure

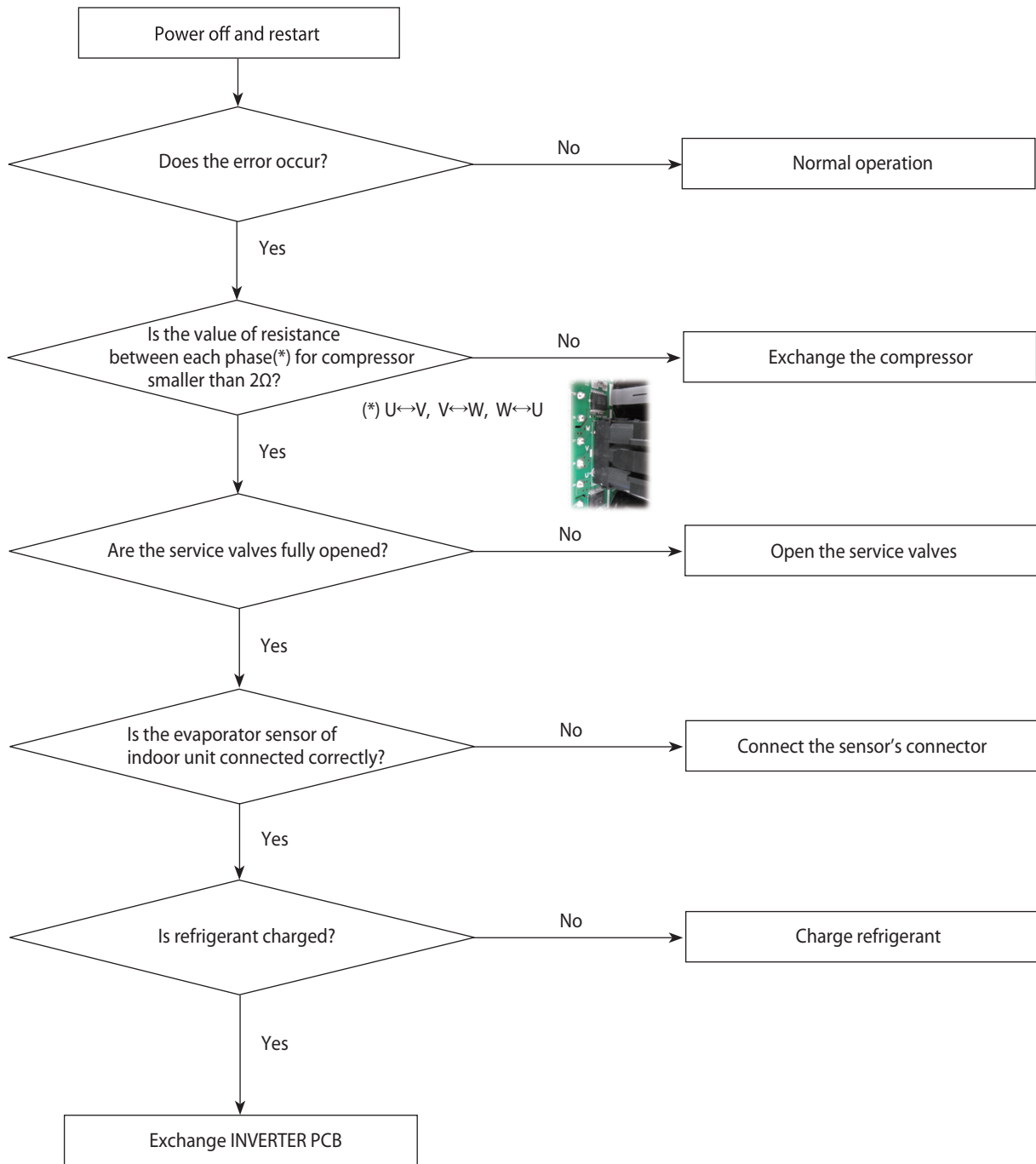

### 4-5-10 The other errors

Error code	Meaning	Troubleshooting
E177	Emergency stop	Indoor unit (Hydro Unit ) orders emergency stop. Check the indoor unit (Hydro Unit).
E201	Hydro Unit quantity is mismatched.	Hydro Unit quantity must be matched with outdoor unit 1 by 1. Check the Hydro Unit quantity. It must be 1EA.
E403	Detection of outdoor freezing when compressor stops.	Outdoor unit (Condenser) froze. Check condenser.
E404	Protection of outdoor overload when compressor stops.	Compressor is overloaded. Please check same as E461 and check compressor when it starts.
E416	Discharge temperature of a compressor in an outdoor unit is overheated.	Discharge temperature is overheated.
E440	Heating operation is not available since the	Check the outdoor temperature.
E441	Cooling operation is not available since the outdoor air temperature is lower than -15°C.	
E465	Compressor over load error	Compressor is overloaded. Please check same as E461 and check compressor when it starts.
E468	Current sensor error	Exchange INVERTER PBA.
E471	Outdoor EEPROM error	EEPROM date is wrong. Exchange EEPROM or MAIN PBA. This error don't occur in EMF 150-AM)
E474	IPM(IGBT Module) or PFCM temperature sensor error	Exchange INVERTER PBA.
E484	PFC overload error	Check reactor located in control plate. If reactor is normal, exchange INVERTER PBA.
E500	IPM is over heated.	Check INVERTER PBA's temperature. Power off and cool down INVERTER PBA, and then restart the outdoor unit.
E556	Capacity mismatching between indoor and outdoor.	EEPROM data is wrong. Exchange EEPROM or MAIN PBA
E557	Option code miss matching among the indoors(only for DPM)	Option setting data is wrong. (This error don't occur in EMF 150-AM)
E590	Inverter EEPROM loading error	Check EEPROM DATA. Check the normal operation of PCB.

### 4-2-11 In case of heating at the cooling mode or cooling at the heating mode

1. Troubleshooting procedure

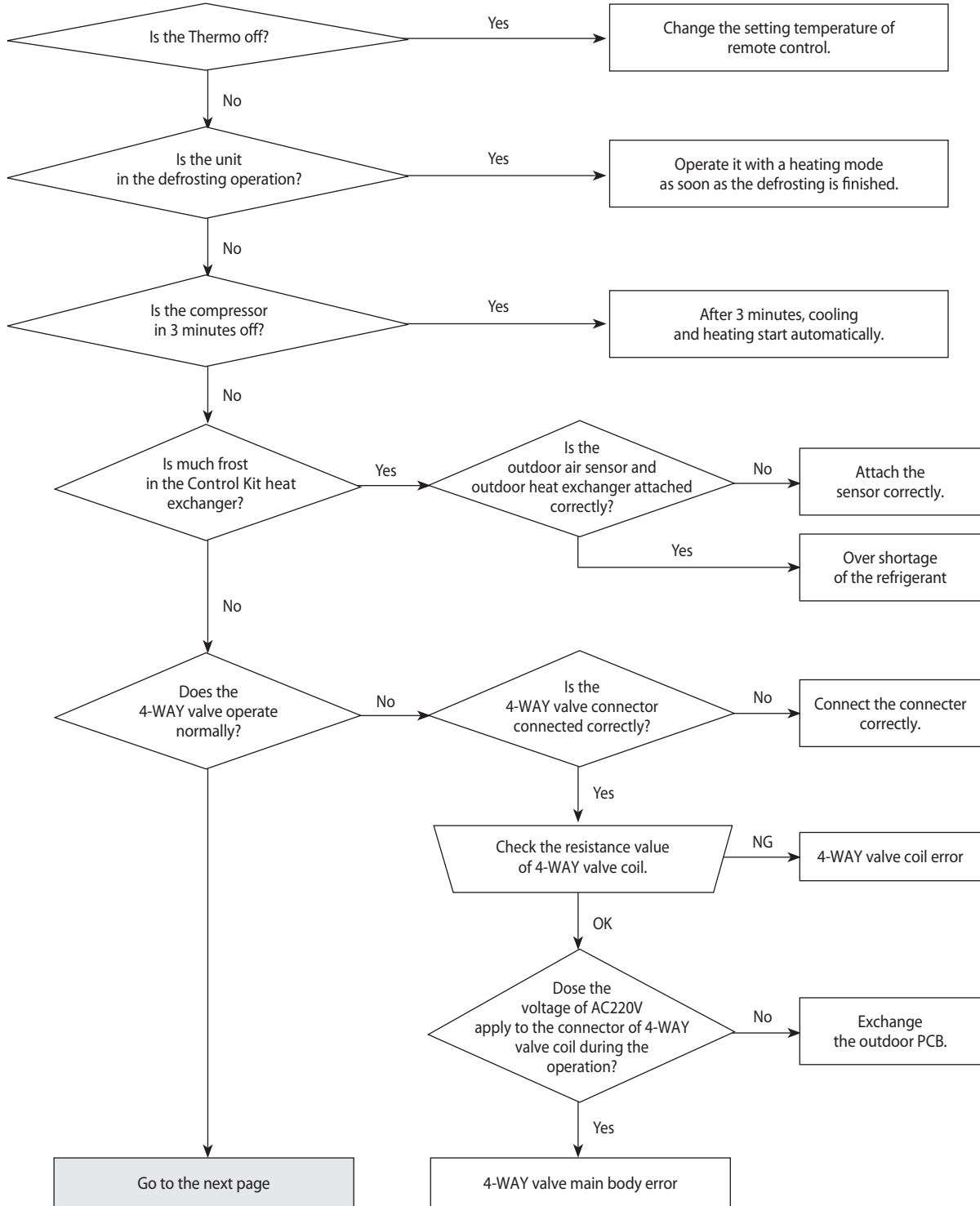

\* Normal resistance value of 4 way valve coil :  $1.5 \pm 0.15k\Omega$  (at 20°C)

**In case of heating at the cooling mode or cooling at the heating mode (cont.)**

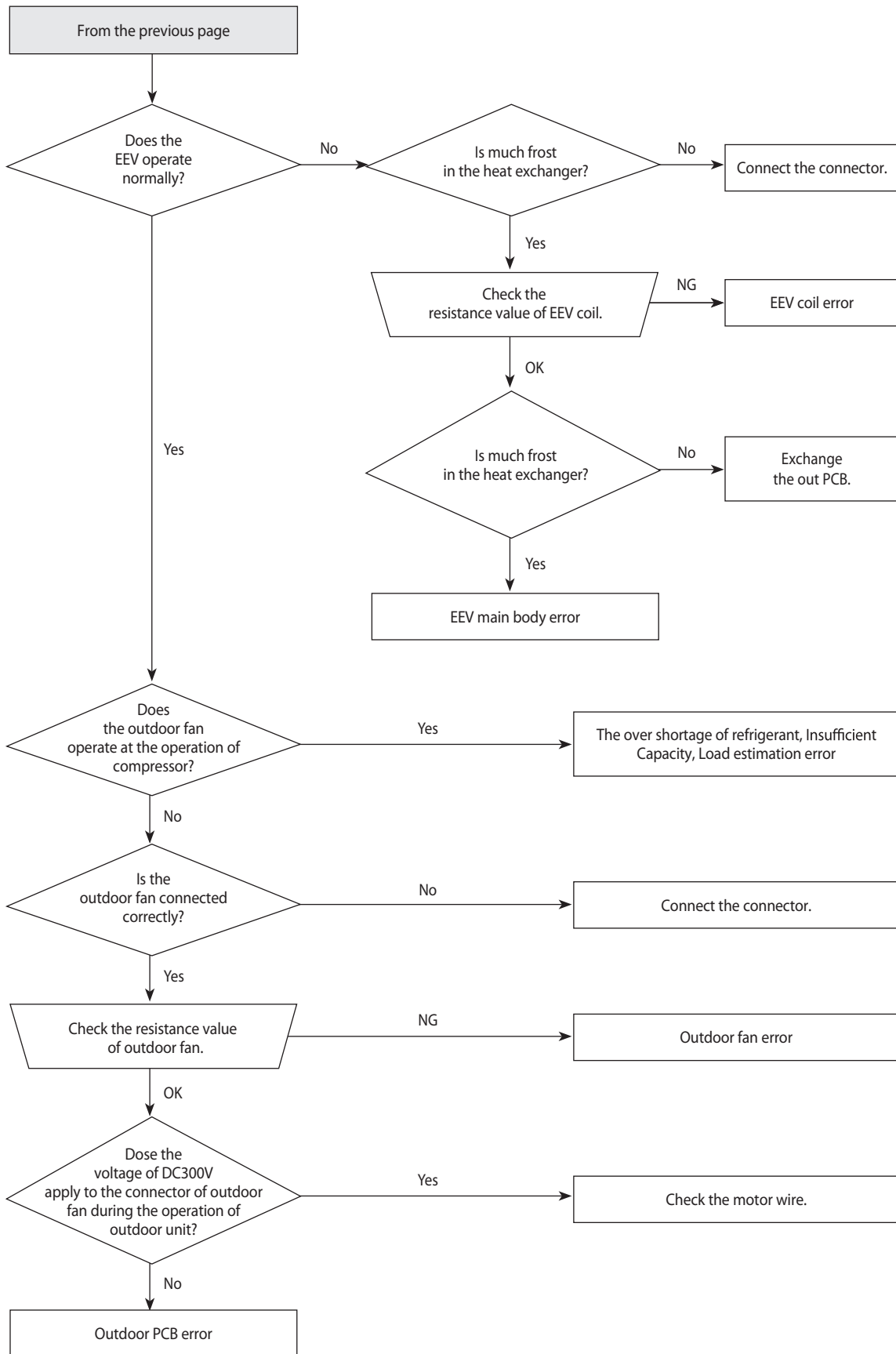

\* Normal resistance value of EEV valve coil(Red-Black or Yellow-Orange) :  $92 \pm 8\Omega$  (at 20°C)

### 4-5-12 Outdoor unit is not powered on – Initial diagnosis

1. Check items
  - 1) Is the power supply voltage 380V?
  - 2) Is the AC power connected correctly?
  - 3) Are the LEDs in the main PCB and inverter PCB of the outdoor unit ON?
  - 4) Is the input power voltage of the indoor unit 220V?
  - 5) Is the wired remote controller connected correctly?
2. Check procedure

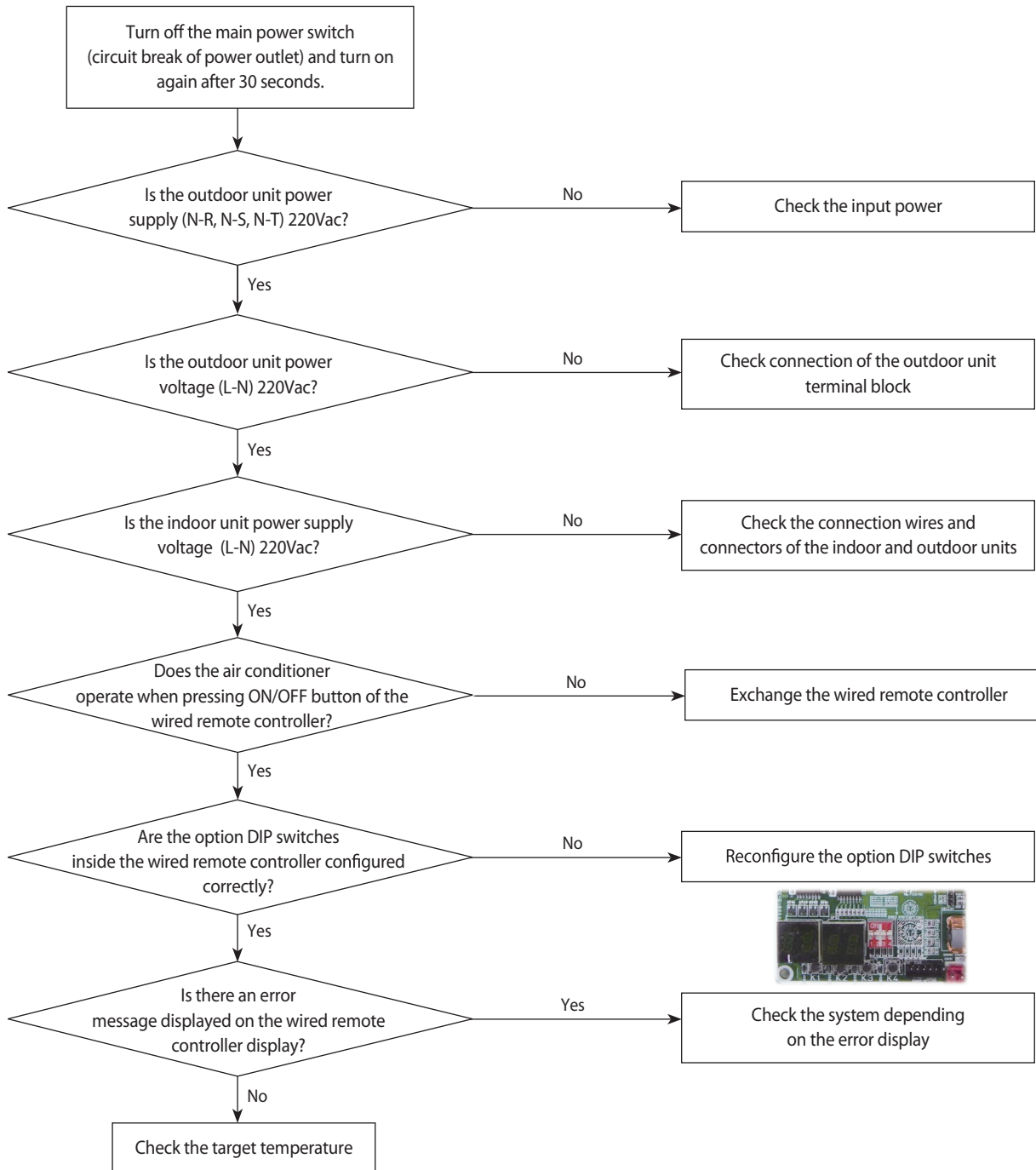

### 4-5-13 Outdoor unit power supply error

1. Checklist:
  - 1) Are the input power voltage and power connection correct?
  - 2) Is there any Fuse Short of the indoor or outdoor unit?
  - 3) Is any LED lit on both MAIN PCB and INVERTER PCB?
  - 4) Are Reactor wires of the outdoor unit connected correctly?

2. Troubleshooting procedure

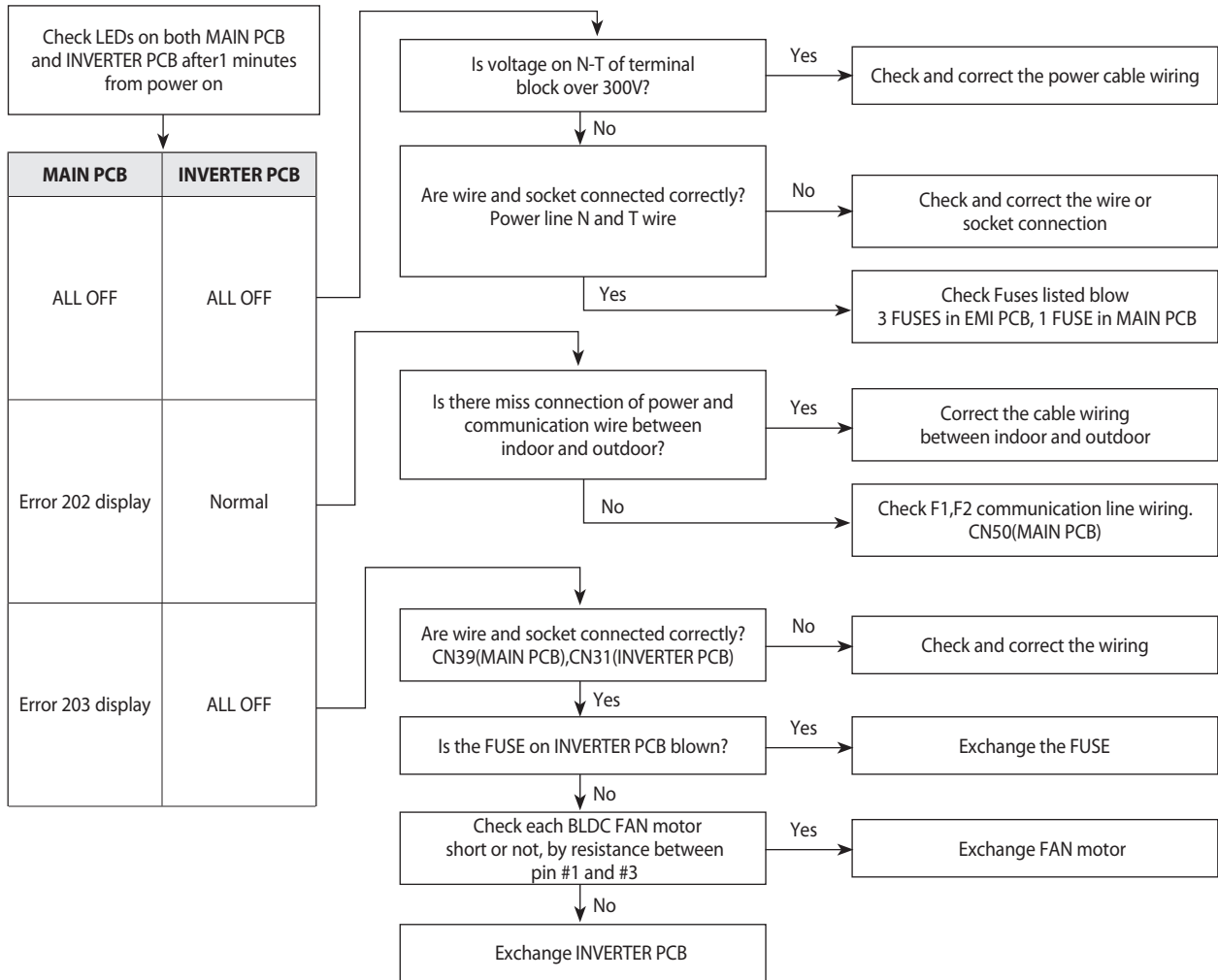



---

## 5. PCB Diagram

---

### 5-1 CONTROL KIT

---

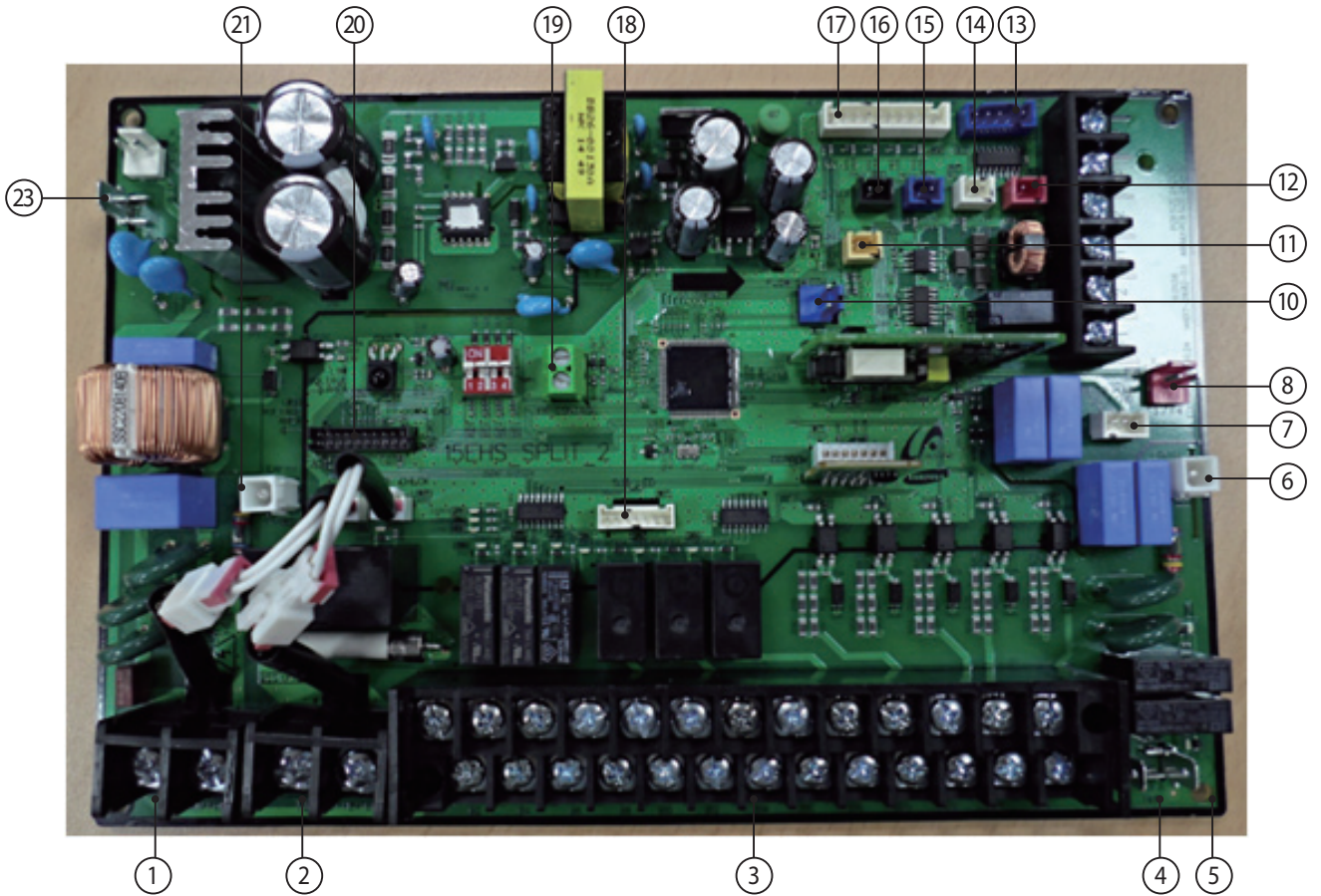

This Document can not be used without Samsung's authorization.

No.	Local	Function	Description
1	TB-A	MAIN POWER	DAPC 3013-2P BLK
2	TB-A1	BOOST HEATER	DAPC 3013-2P BLK
3	TB-B	EXTERNAL CONTROL	BR-1000C2-26P BLK
4	CNP001	MC2-A	YTR250
5	CNP002	MC1-A	YTR250
6	CN303	EARTH	YDW236-01 WHT
7	CNS1	WATER PUMP SIG/GND	SMW250-03 WHT
8	CNS304	WIRED REMOCON F3/F4	YW396-02V RED
9	TB-C	F1-F2/DC12V-GND/F3-F4	DAPC 2009-6P BLK
10	CNS041	FLOW SWITCH	YW396-02V BLU
11	CNS042	WATER TANK	SMW250-02 YEL
12	CNS046	SMART GRID	SMW250-02 RED
13	CNS062	EEV	SMW250-05 BLU
14	CNS044	ROOM	SMW250-02 WHT
15	CNS045	MIXING SENSOR	SMW250-02 BLU
16	CNS047	HEATER	SMW250-02 BLK
17	CNS043	HEATER/EVA-OUT/EVA-IN/WATER-OUT/WATER-IN	SMW250-10 WHT
18	CNS201	SUB_LED	SMW200-07 WHT
19	CNS2	FR_CONTROL	AKZ350 GRN
20	CNS301	DOWNLOAD	YDW200-20 BLK
21	CN101	EARTH	YDW236-01 WHT
22	CNP401	B/UP HEATER_N	YW396-02V WHT
23	CNP003	MC2-B	YTR250

## 5-2 Outdoor Unit

### INVERTER PCB AE050JXYDEH

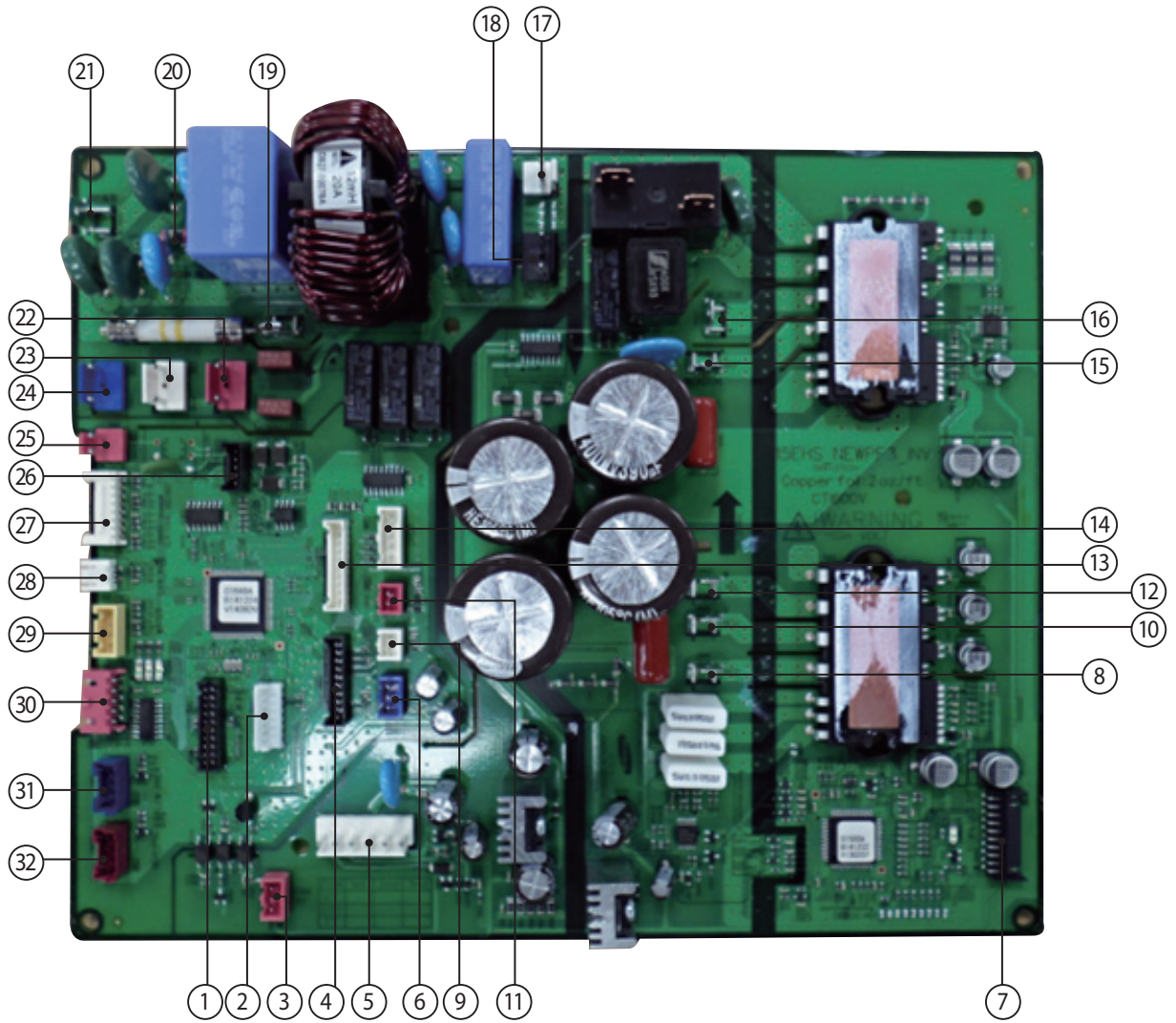

This Document can not be used without Samsung's authorization.

No.	Local	Function	Description
1	CN201	DOWNLOAD-MAIN	YDW200-20 BLK
2	CN202	EEPROM	B7P-MQ WHT
3	CN153	SMPS DC15V	SMW250-03 RED
4	CN207	SUB PBA	SMW200-10 BLK
5	CN901	BLDC MOTOR	YW396-06V WHT
6	CN152	SMPS DC12V	SMW250-03 BLU
7	CN551	DOWNLOAD-MAIN	YDAW200-20 BLK
8	CN401	COMP_U	YTR250
9	CN203	TB-FUSE	SMW250-02 WHT
10	CN402	COMP_V	YTR250
11	CN246	QUIET_SW	SMW250-02 RED
12	CN403	COMP_W	YTR250
13	CN206	SUB PBA	SMW200-10 WHT
14	CN204	DRED	SMW250-05 WHT
15	CN051	REACTOR	YTR250
16	CN052	REACTOR	YTR250
17	CN150	SMPS POWER	YW396-03 BLK
18	CN151	HIGH-PRESS S/W	YW396-02V WHT
19	CN002	POWER	YTR250
20	CN003	EARTH	GP881205
21	CN001	POWER	YTR250
22	CN241	HOT GAS	YW396-03AV RED
23	CN030	4WAY	YW396-03AV WHT
24	CN242	BASE-HEATER	YW396-03AV BLU
25	CN301	COMM	YW396-02V RED
26	CN205	SUB PBA	SMW200-05 BLK
27	CN251	SENSOR OLP/COND/DIS/OUT	SMAW200-08 WHT
28	CN245	EVA_IN	SMAW250-02 WHT
29	CN252	WATER	SMW250-04 YEL
30	CN701	EEV	SMAW250A-05 RED
31	CN801	LOW-PRESS SENSOR	B04B-XAEK-1
32	CN809	HIGH-PRESS SENSOR	B04B-XARK-1

**SUB-DISPLAY PCB  
AE050JXYDEH**

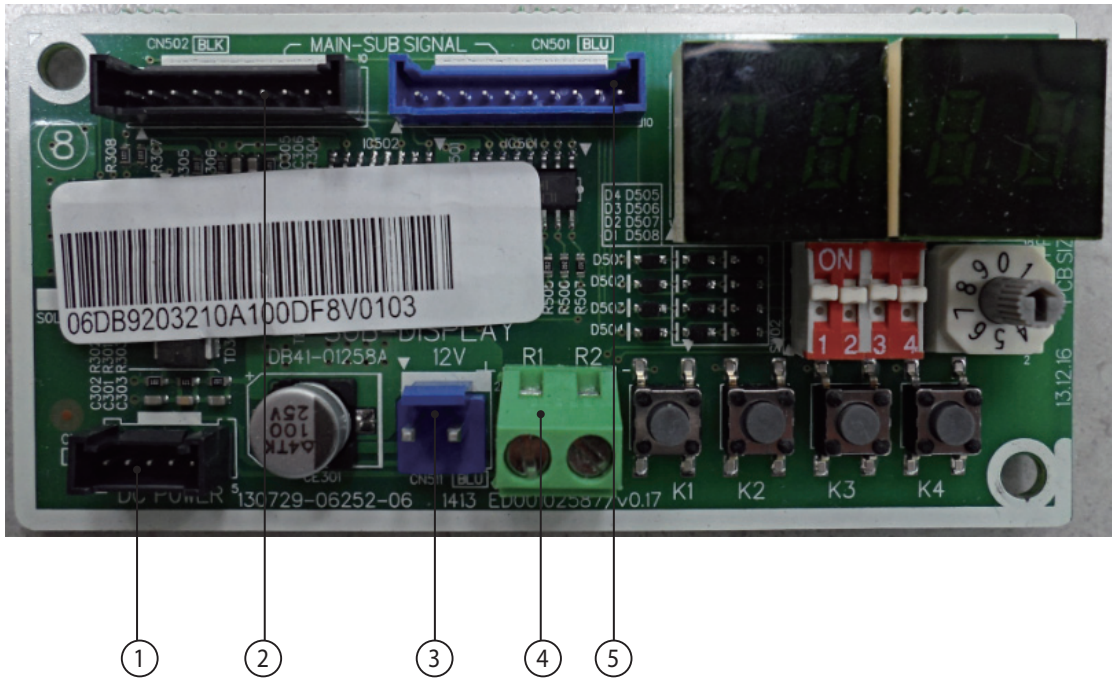

This Document can not be used without Samsung's authorization.

No.	Local	Function	Description
1	CN518	DC POWER	SMW200-05 BLK
2	CN502	MAIN-SUB SIGNAL	SMW200-10 BLK
3	CN511	DC 12V	YW396-02V BLU
4	CN01	SOLUTION_COMM	AKZ350 GRN
5	CN501	MAIN-SUB SIGNAL	SMW200-10 BLU



# 6. Wiring Diagram

## 6-1 Control Kit

This Document can not be used without Samsung's authorization.

Resistance value of temperature sensor at 25°C(77°F)

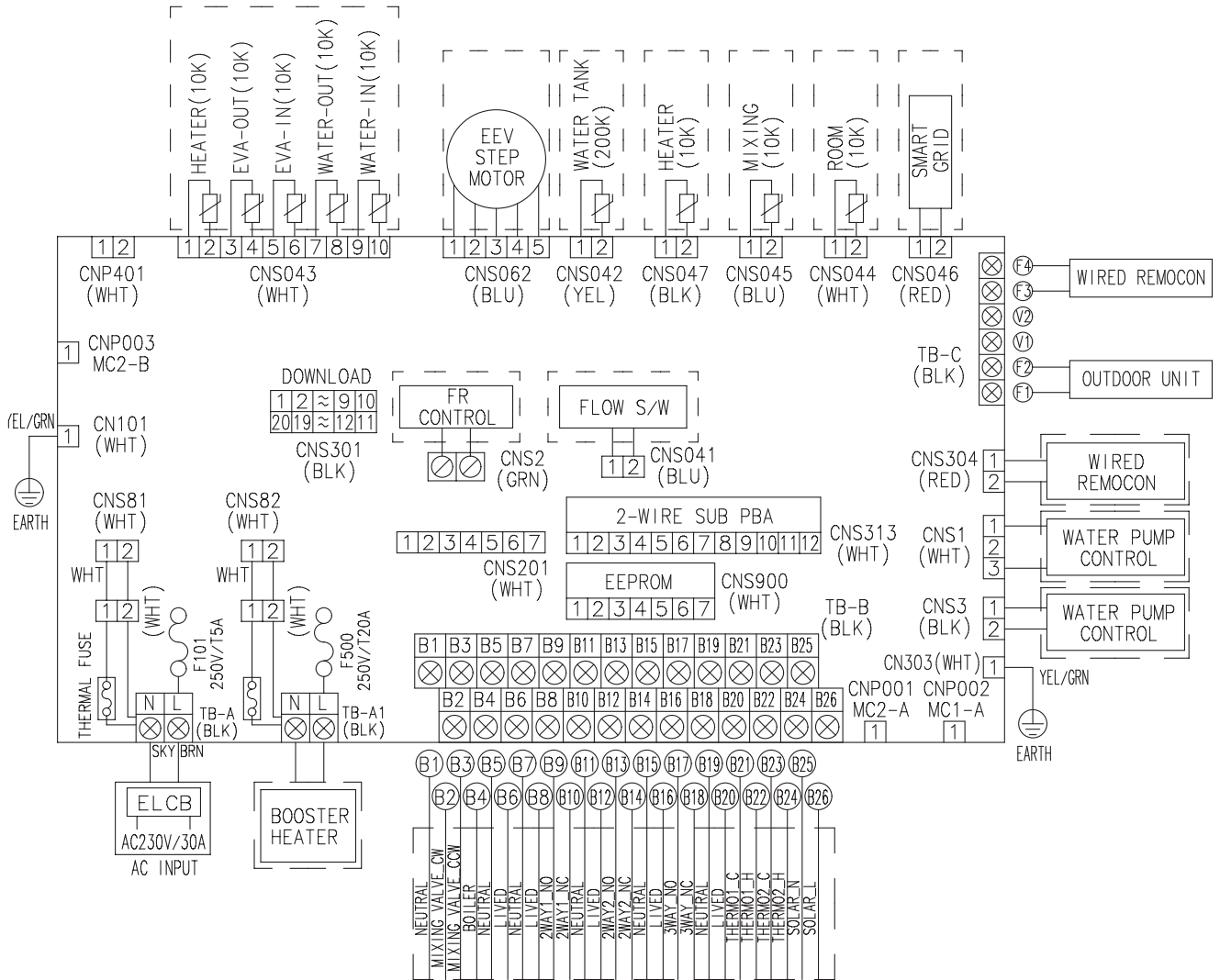

\*NOT SUPPLIED PARTS

This Document can not be used without Samsung's authorization.

# 6-2 Outdoor Unit

1Phase (AE050JXYDEH)

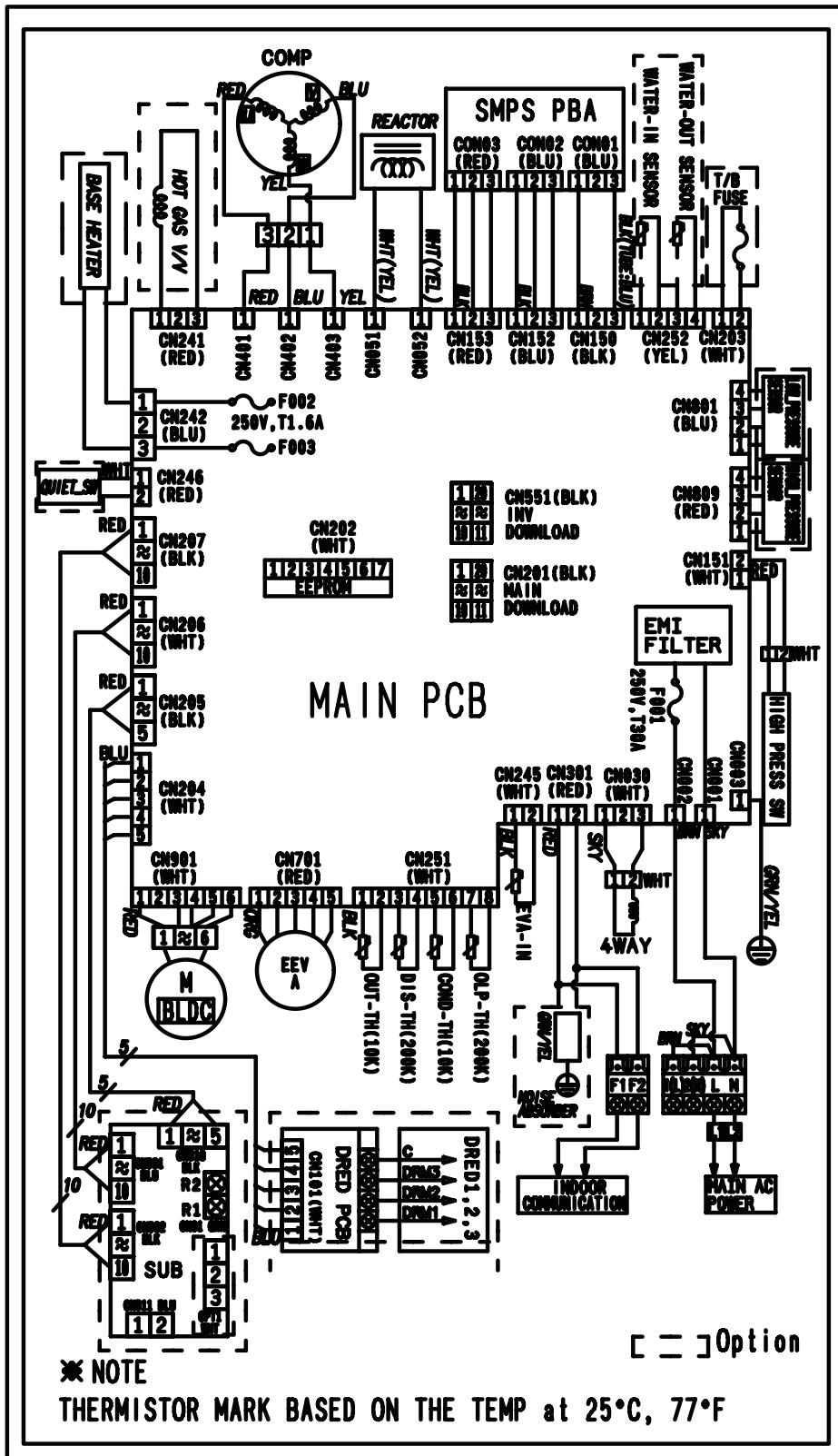

This Document can not be used without Samsung's authorization.

# 7. Reference Sheet

## 7-1 Index for Model Name

### 7-1-1 Outdoor Unit

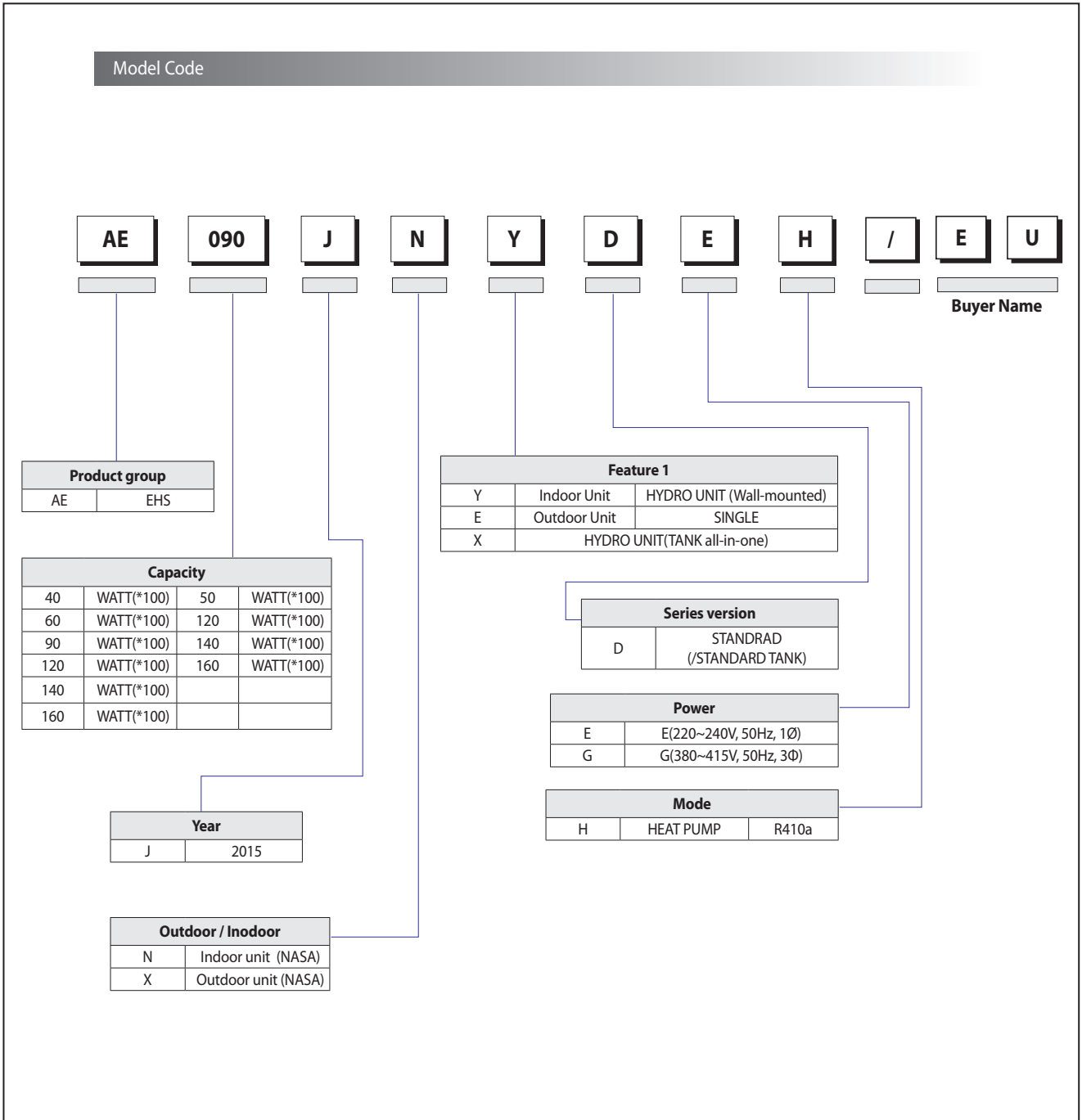



## 7-2 Refrigerant Circuit Diagram

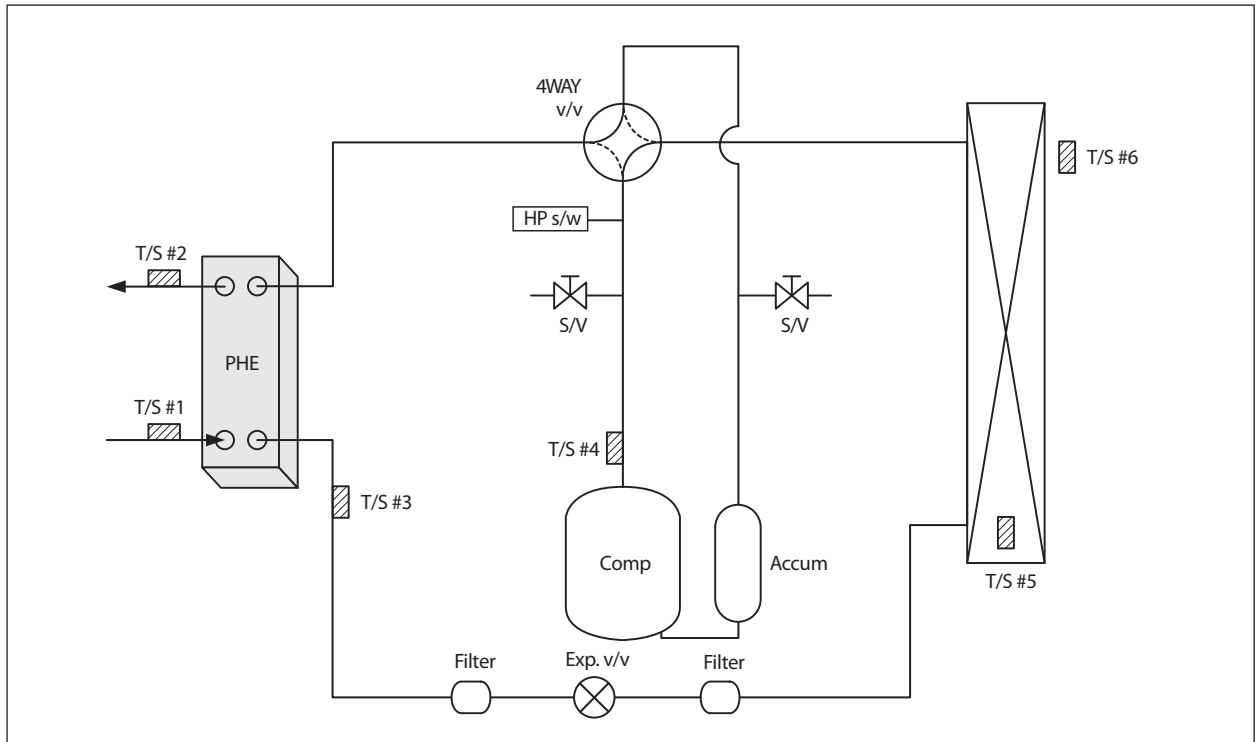

Part	Description
PHE	Plate heat exchanger
T/S #1	For water inlet temp sensor
T/S #2	For water outlet temp sensor
T/S #3	For PHE temp sensor
T/S #4	For discharge temp
T/S #5	For cond temp
T/S #6	For ambient temp sensor
S/V	Service valve ¼ inch
Accum	Accumulator
Exp. V/V	Expansion Valve
HP S/W	High Pressure Switch

\* The Direction of this product 4WAY V/V connection is heating default.  
(Heating : 4Way valve Off, Cooling : 4Way valve ON)

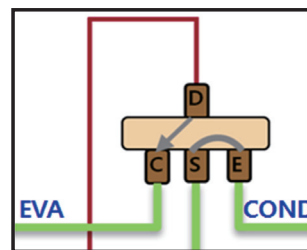
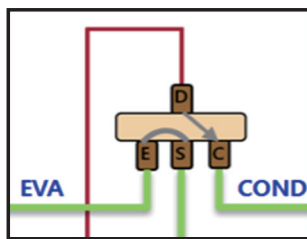

## 7-3 FSV data check and update using S-Net Pro2

To check the EHS HE / HT FSV data the [Update] button must be selected.

The screenshot shows the S-Net Pro2 software interface. At the top, there is a menu bar with 'Home', 'Trend Graph', 'Add-On', and 'Help'. Below the menu bar is a toolbar with various icons and buttons: 'Disconnect', 'Controller', 'Control for Unoccupied Room Controller', 'On Recording', 'Open Record Folder', 'Reset to Default Layout', 'Report Wizard Management', and 'Control Unit' (set to 10.04.00). The main area displays the 'EHS HE FSV' data table. The table has columns for 'Address', '0', and '1'. The 'Update' button is highlighted in the top left corner of the table area.

Address	0	1
1011.Max- Temperature of general c	23°C	-
1012.Min- Temperature of general c	15°C	-
1021.Max- General Indoor cooling te	28°C	-
1022.Min- General Indoor cooling te	18°C	-
1031.Max- Temperature of general h	46°C	-
1032.Min- Temperature of general h	26°C	-
1041.Max- General indoor heating te	30°C	-
1042.Min- General indoor heating te	16°C	-
1051.Max- Temperature of hot water	50°C	-
1052.Min- Temperature of hot water	35°C	-
2011.Max- Auto heating ambient tem	-14°C	-
2012.Min- Auto heating ambient tem	15°C	-
2021.Max- Temperature of auto heat	45°C	-
2022.Min- Temperature of auto heat	29°C	-
2031.Max- Temperature of auto heat	63°C	-
2032.Max- Temperature of auto heat	35°C	-
2041.v/L type- Auto heating of wired	1.Floor	-
2091.#1(Floor)- Use of thermostat -	No	-
2092.#2(FCU)- Use of thermostat - W	Yes	-
3011.DH/W application- Activating hot	Yes	-
3021.Max- Heat pump - DH/W	48°C	-
3022.Stop- Heat pump - DH/W	3°C	-
3023.Start- Heat pump - DH/W	5°C	-
3024.Min. hour- Heat pump - DH/W	5	-

FSV value has been updated, double-click each cell can set the value of the FSV.

The screenshot shows the S-Net Pro2 software interface with the 'EHS HE FSV' data table. A 'User Command' dialog box is open, allowing the user to edit the value for the cell '1032.Min- Temperature of general heating discharge water - Remote Controller'. The current value is 26. The dialog box has 'OK' and 'Cancel' buttons.

Address	0	1
1011.Max- Temperature of general c	23°C	-
1012.Min- Temperature of general c	15°C	-
1021.Max- General Indoor cooling te	28°C	-
1022.Min- General Indoor cooling te	18°C	-
1031.Max- Temperature of general h	46°C	-
1032.Min- Temperature of general h	26°C	-
1041.Max- General indoor heating te	30°C	-
1042.Min- General indoor heating te	16°C	-
1051.Max- Temperature of hot water	50°C	-
1052.Min- Temperature of hot water	35°C	-
2011.Max- Auto heating ambient tem	-14°C	-
2012.Min- Auto heating ambient tem	15°C	-
2021.Max- Temperature of auto heat	45°C	-
2022.Min- Temperature of auto heat	29°C	-
2031.Max- Temperature of auto heat	63°C	-
2032.Max- Temperature of auto heat	35°C	-
2041.v/L type- Auto heating of wired	1.Floor	-
2091.#1(Floor)- Use of thermostat -	No	-
2092.#2(FCU)- Use of thermostat - W	Yes	-
3011.DH/W application- Activating hot	Yes	-
3021.Max- Heat pump - DH/W	48°C	-
3022.Stop- Heat pump - DH/W	3°C	-
3023.Start- Heat pump - DH/W	5°C	-
3024.Min. hour- Heat pump - DH/W	5	-

## 7-4 EHS FSV Values Import and Export

The User can now export the existing FSV values into an XML file and update later onto a new unit the saved values.

The screenshot shows the EHS HE FSV software interface. At the top, there is a menu bar with 'Home', 'Trend Graph', 'Add-On', and 'Help'. Below the menu are several icons for 'Disconnect', 'Controller', 'Control for Unoccupied Room', 'On Recording', 'Open Record Folder', 'Reset to Default Layout', and 'Report Wizard'. The 'Control Unit' is set to '10.04.00'. The main area displays a table titled 'FSV 1' with columns for 'Address', '0', and '1'. The table is split into two panes, showing various parameters like temperature, operation status, and disinfection settings.

Address	0	1
1011.Max- Temperature of general c	23°C	-
1012.Min- Temperature of general c	15°C	-
1021.Max- General Indoor cooling te	28°C	-
1022.Min- General Indoor cooling te	18°C	-
1031.Max- Temperature of general h	45°C	-
1032.Min- Temperature of general h	26°C	-
1041.Max- General indoor heating te	30°C	-
1042.Min- General indoor heating te	16°C	-
1051.Max- Temperature of hot water	50°C	-
1052.Min- Temperature of hot water	35°C	-
2011.Max- Auto heating ambient tem	-14°C	-
2012.Min- Auto heating ambient tem	15°C	-
2021.Max- Temperature of auto heat	45°C	-
2022.Min- Temperature of auto heat	29°C	-
2031.Max- Temperature of auto heat	63°C	-
2032.Max- Temperature of auto heat	35°C	-
2041.InL type- Auto heating of aired	1.Floor	-
2091.#1(Floor)- Use of thermostat -	No	-
2092.#2(FCU)- Use of thermostat - W	Yes	-
3011.DHW application- Activating hot	Yes	-
3021.Max- Heat pump - DHW	48°C	-
3022.Stop- Heat pump - DHW	3°C	-
3023.Start- Heat pump - DHW	5°C	-
3031.Operation- Booster heater - DH	Yes	-
3032.Delayed time- Booster heater -	20	-
3033.Overshoot- Booster heater - DH	4°C	-
3034.Delayed time- Booster heater -	11°C	-
3041.Operation- Disinfection - DHW	No	-
3042.Operation interval- Disinfection	Everyd	-
3043.Start time- Disinfection - DHW	22	-
3044.Target temp- Disinfection - DH	70°C	-
3045.Holding time- Disinfection - DH	10	-
3061.H/P interlocking- Solar heat pan	No	-
4011.Heating/hot water priority- Heat	DHW	-
4012.Heating priority- Heat pump - H	0°C	-
4013.Heating Off- Heat pump - Heat	27°C	-
4014.Overshoot- Heat pump - Heatin	2°C	-
5011.Temperature of cooling water o	25°C	-
5012.Room Temperature of cooling	30°C	-
5013.Temperature of heating dischar	15°C	-
5014.Indoor heating temperature- Ou	16°C	-
5017.Temperature of auto heating W	15°C	-
5018.Temperature of auto heating W	16°C	-
5019.Temperature of hot water Tank-	30°C	-
5021.Temperature of hot water Tank-	5°C	-
5041.Operation- Benefit kWh (Power)	No	-



## Export Values:

The existing FSV values can be exported by click on the "Export" button.

The screenshot shows the S-NET pro 2 - DVM 5 NASA software interface. The main window displays a list of FSV values for 'FSV 1' with columns for Address, Value, and Unit. A dialog box titled 'FSV Export' is open in the center, prompting the user to 'Select Device Address' with a dropdown menu showing '20.04.00' and an 'OK' button.

Address	Value	Unit
1011.Max - Temperature of general c	23°C	
1012.Min - Temperature of general c	15°C	
1021.Max - General Indoor cooling te	28°C	
1022.Min - General Indoor cooling te	18°C	
1031.Max - Temperature of general h	46°C	
1032.Min - Temperature of general h	26°C	
1041.Max - General indoor heating te	30°C	
1042.Min - General indoor heating te	16°C	
1051.Max - Temperature of hot water	50°C	
1052.Min - Temperature of hot water	35°C	
2011.Max - Auto heating ambient tem	-14°C	
2012.Min - Auto heating ambient tem	15°C	
2021.Max - Temperature of auto heat	45°C	
2022.Min - Temperature of auto heat	29°C	
2031.Max - Temperature of auto heat	63°C	
2032.Max - Temperature of auto heat	35°C	
2041.VL type- Auto heating of wired	1.Floor	
2091.#1(Floor)- Use of thermostat -	No	
2092.#2(FCU)- Use of thermostat - V	Yes	
3011.DH/W application- Activating hot	Yes	
3021.Max - Heat pump - DH/W	48°C	
3022.Stop - Heat pump - DH/W	3°C	
3023.Start - Heat pump - DH/W	5°C	

The screenshot shows the S-NET pro 2 - DVM 5 NASA software interface. The main window displays a list of FSV values for 'FSV 1' with columns for Address, Value, and Unit. A dialog box titled 'FSV Export' is open in the center, displaying a success message: 'Successfully Exported' with an 'OK' button.

Address	Value	Unit
1011.Max - Temperature of general c	23°C	
1012.Min - Temperature of general c	15°C	
1021.Max - General Indoor cooling te	28°C	
1022.Min - General Indoor cooling te	18°C	
1031.Max - Temperature of general h	46°C	
1032.Min - Temperature of general h	26°C	
1041.Max - General indoor heating te	30°C	
1042.Min - General indoor heating te	16°C	
1051.Max - Temperature of hot water	50°C	
1052.Min - Temperature of hot water	35°C	
2011.Max - Auto heating ambient tem	-14°C	
2012.Min - Auto heating ambient tem	15°C	
2021.Max - Temperature of auto heat	45°C	
2022.Min - Temperature of auto heat	29°C	
2031.Max - Temperature of auto heat	63°C	
2032.Max - Temperature of auto heat	35°C	
2041.VL type- Auto heating of wired	1.Floor	
2091.#1(Floor)- Use of thermostat -	No	
2092.#2(FCU)- Use of thermostat - V	Yes	
3011.DH/W application- Activating hot	Yes	
3021.Max - Heat pump - DH/W	48°C	
3022.Stop - Heat pump - DH/W	3°C	
3023.Start - Heat pump - DH/W	5°C	
3024.Min. hour- Heat pump - DH/W	5	

## FSV Import:

The FSV values can be imported by the click on the import button.

The user is prompted to browse and select the XML file for update on the EHS unit selected in the dropdown menu.

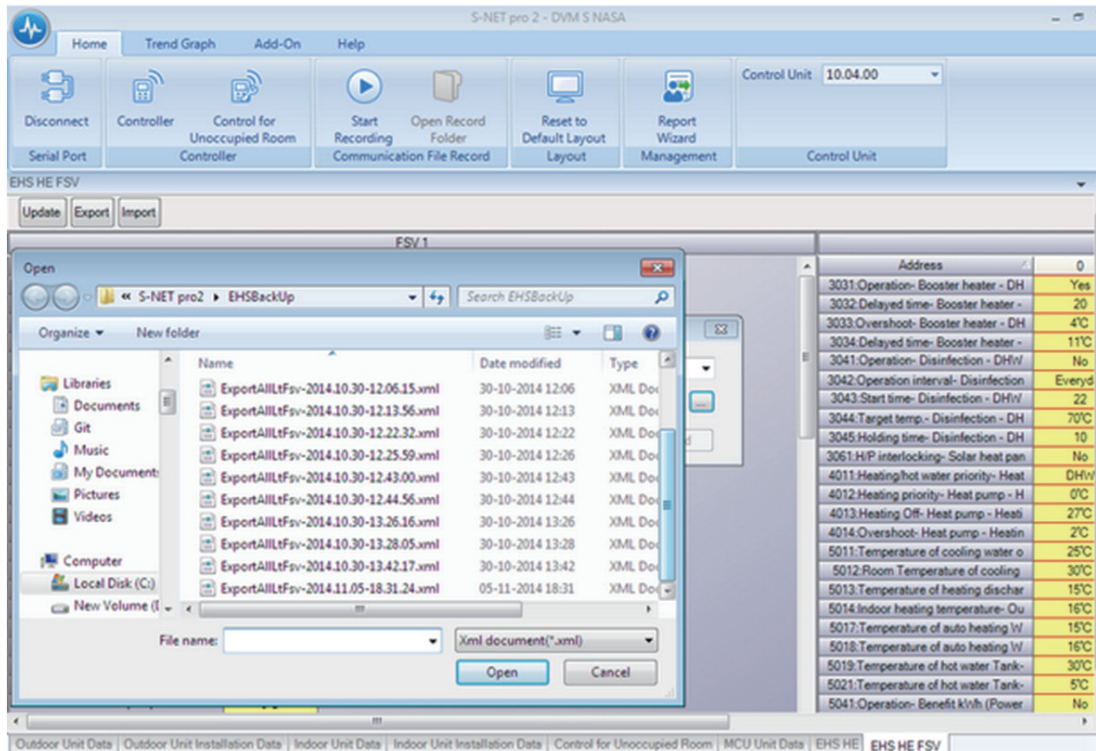
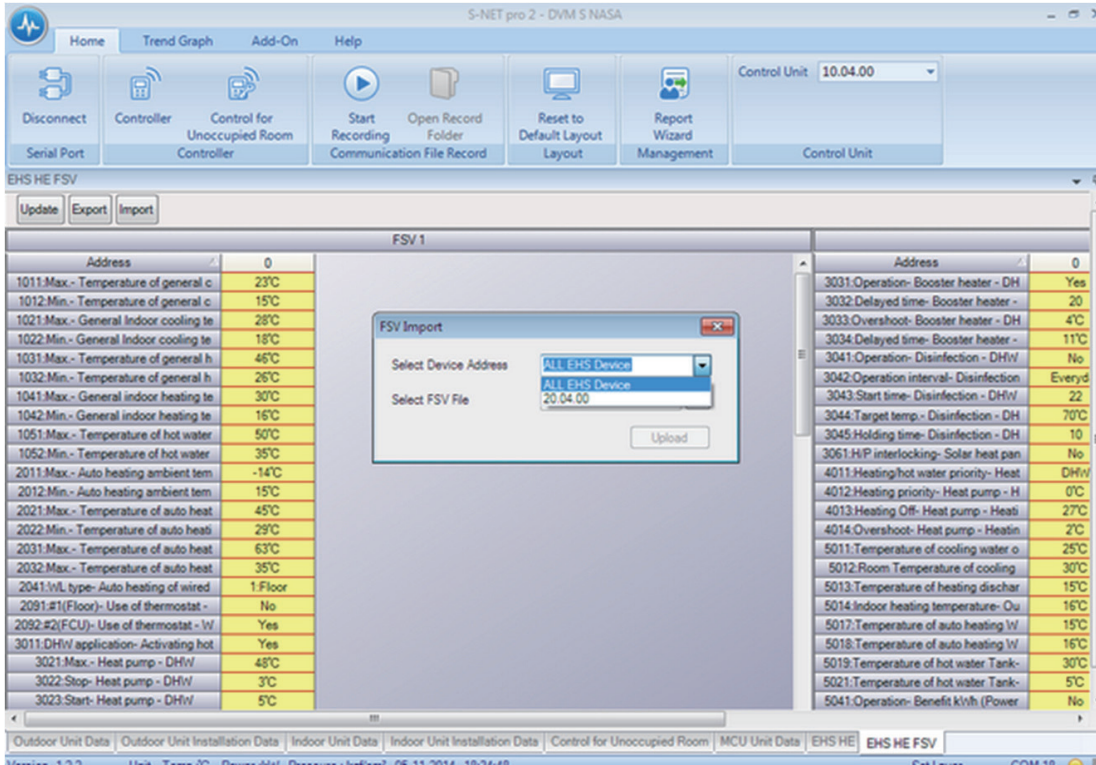

S-NET pro 2 - DVM S NASA

Home Trend Graph Add-On Help

Control Unit 10.04.00

Disconnect Controller Control for Unoccupied Room Controller Start Recording Open Record Folder Reset to Default Layout Report Wizard Management Control Unit

BHS HE FSV

FSV 1

Address	Value	Address	Value
1011.Max- Temperature of general c	23°C	3031.Operation- Booster heater - DH	Yes
1012.Min- Temperature of general c	15°C	3032.Delayed time- Booster heater -	20
1021.Max- General Indoor cooling te	28°C	3033.Overshoot- Booster heater - DH	4°C
1022.Min- General Indoor cooling te	18°C	3034.Delayed time- Booster heater -	11°C
1031.Max- Temperature of general h	45°C	3041.Operation- Disinfection - DH/V	No
1032.Min- Temperature of general h	26°C	3042.Operation interval- Disinfection	Everyd
1041.Max- General indoor heating te	30°C	3043.Start time- Disinfection - DH/V	22
1042.Min- General indoor heating te	16°C	3044.Target temp- Disinfection - DH	70°C
1051.Max- Temperature of hot water	50°C	3045.Holding time- Disinfection - DH	10
1052.Min- Temperature of hot water	35°C	3061.H/P interlocking- Solar heat pan	No
2011.Max- Auto heating ambient tem	-14°C	4011.Heating/hot water priority- Heat	DH/V
2012.Min- Auto heating ambient tem	15°C	4012.Heating priority- Heat pump - H	0°C
2021.Max- Temperature of auto heat	45°C	4013.Heating Off- Heat pump - Heat	27°C
2022.Min- Temperature of auto heat	29°C	4014.Overshoot- Heat pump - Heatin	2°C
2031.Max- Temperature of auto heat	63°C	5011.Temperature of cooling water o	25°C
2032.Max- Temperature of auto heat	35°C	5012.Room Temperature of cooling	30°C
2041.VL type- Auto heating of wired	1 Floor	5013.Temperature of heating dischar	15°C
2091.#1(Floor)- Use of thermostat -	No	5014.Indoor heating temperature- Ou	16°C
2092.#2(FCU)- Use of thermostat - V	Yes	5017.Temperature of auto heating V	15°C
3011.DH/V application- Activating hot	Yes	5018.Temperature of auto heating V	16°C
3021.Max- Heat pump - DH/V	48°C	5019.Temperature of hot water Tank-	30°C
3022.Stop- Heat pump - DH/V	3°C	5021.Temperature of hot water Tank-	5°C
3023.Start- Heat pump - DH/V	5°C	5041.Operation- Benefit kWh (Power	No
3024.Min. hour- Heat pump - DH/V	5	5042.Heat source for operation limit-	0

FSV Import

Successfully Imported

OK

Outdoor Unit Data | Outdoor Unit Installation Data | Indoor Unit Data | Indoor Unit Installation Data | Control for Unoccupied Room | MCU Unit Data | EHS HE | EHS HE FSV

Version 1.2.2 Unit - Temp.°C Power kW Pressure : kgf/cm² 05-11-2014 18:36:40 Set Layer COM 18



This Service Manual is a property of Samsung Electronics Co., Ltd.  
Any unauthorized use of Manual can be punished under applicable  
International and/or domestic law.

© Samsung Electronics Co., Ltd. June. 2015.  
Printed in China.  
Code No. DB68-15061(1)